



OPERATING INSTRUCTIONS

EN

Translation of the Original

HENA 401 | 631

Rotary vane pump

PFEIFFER  **VACUUM**



Dear Customer,

Thank you for choosing a Pfeiffer Vacuum product. Your new rotary vane pump is designed to support you by its performance, its perfect operation and without interfering your individual application. The name Pfeiffer Vacuum stands for high-quality vacuum technology, a comprehensive and complete range of top-quality products and first-class service. With this expertise, we have acquired a multitude of skills contributing to an efficient and secure implementation of our product.

Knowing that our product must not interfere with your actual work, we are convinced that our product offers you the solution that supports you in the effective and trouble-free execution of your individual application.

Please read these operating instructions before putting your product into operation for the first time. If you have any questions or suggestions, please feel free to contact info@pfeiffer-vacuum.de.

Further operating instructions from Pfeiffer Vacuum can be found in the [Download Center](#) on our website.

Disclaimer of liability

These operating instructions describe all models and variants of your product. Note that your product may not be equipped with all features described in this document. Pfeiffer Vacuum constantly adapts its products to the latest state of the art without prior notice. Please take into account that online operating instructions can deviate from the printed operating instructions supplied with your product.

Furthermore, Pfeiffer Vacuum assumes no responsibility or liability for damage resulting from the use of the product that contradicts its proper use or is explicitly defined as foreseeable misuse.

Copyright

This document is the intellectual property of Pfeiffer Vacuum and all contents of this document are protected by copyright. They may not be copied, altered, reproduced or published without the prior written permission of Pfeiffer Vacuum.

We reserve the right to make changes to the technical data and information in this document.



Table of contents

1	About this manual	7
1.1	Validity	7
	1.1.1 Applicable documents	7
	1.1.2 Variants	7
1.2	Target group	7
1.3	Conventions	7
	1.3.1 Instructions in the text	7
	1.3.2 Pictographs	8
	1.3.3 Stickers on the product	8
	1.3.4 Abbreviations	9
1.4	Trademark proof	9
2	Safety	10
2.1	General safety information	10
2.2	Safety instructions	10
2.3	Safety precautions	14
2.4	Limits of use of the product	15
2.5	Proper use	15
2.6	Foreseeable improper use	15
2.7	Personnel qualification	16
	2.7.1 Ensuring personnel qualification	16
	2.7.2 Personnel qualification for maintenance and repair	16
3	Product description	18
3.1	Function	18
	3.1.1 Operating fluid	18
	3.1.2 Cooling	19
	3.1.3 Gas ballast system	19
	3.1.4 Operating fluid return via the float valve	19
3.2	Identifying the product	19
3.3	Product features	19
3.4	Scope of delivery	20
4	Transportation and Storage	21
4.1	Transport	21
4.2	Storing the vacuum pump	22
5	Installation	23
5.1	Setting up the vacuum pump	23
5.2	Connecting the vacuum side	23
5.3	Connecting the exhaust side	24
5.4	Filling the operating fluid	25
5.5	Connect the exhaust gas temperature monitoring	26
5.6	Connecting the oil/water heat exchanger	28
5.7	Establishing mains connection	29
	5.7.1 Connect three phase motor with 6-pin terminal board	30
	5.7.2 Connect three phase motor with 12-pin terminal board	30
	5.7.3 Checking the direction of rotation	31
	5.7.4 Setting the motor protection switch	31
	5.7.5 Frequency inverter for vacuum pumps with 3-phase motor	32
	5.7.6 Connecting the PTC thermistor tripping unit	33
6	Operation	34
6.1	Putting the vacuum pump into operation	34
6.2	Switching on the vacuum pump	34
6.3	Operating the rotary vane pump with gas ballast	36
6.4	Refilling operating fluid	36



6.5	Switching off the vacuum pump	37
7	Maintenance	39
7.1	Maintenance instructions	39
7.2	Checklist for inspection and maintenance	40
7.3	Changing the operating fluid	41
7.3.1	Determine degree of aging of P3 operating fluid	41
7.3.2	Change the operating fluid	42
7.3.3	Rinsing and cleaning the rotary vane vacuum pump	43
7.3.4	Changing the operating fluid filter	44
7.4	Change the exhaust filter in the operating fluid separator	45
7.4.1	Dismantling the exhaust filters	45
7.4.2	Mounting the exhaust filters	46
7.5	Cleaning the intake strainer	46
7.6	Cleaning the gas ballast filter	47
7.7	Cleaning the operating fluid return line	48
7.8	Changing the operating fluid type	50
8	Decommissioning	51
8.1	Shutting down for longer periods	51
8.2	Recommissioning	51
9	Recycling and disposal	52
9.1	General disposal information	52
9.2	Dispose of rotary vane pump	52
10	Malfunctions	53
11	Service solutions by Pfeiffer Vacuum	55
12	Spare parts	57
12.1	Ordering spare part packages	57
12.2	Operating fluids – Maintenance level 1	57
12.3	Maintenance kit – maintenance level 1	57
12.4	Overhaul kit – maintenance level 3	57
12.5	Set of seals	58
12.6	Set of vanes	58
13	Accessories	59
13.1	Accessory information	59
13.2	Ordering accessories	59
14	Technical data and dimensions	60
14.1	General	60
14.2	Technical data	60
14.3	Dimensions	65
	Declaration of conformity	69



List of tables

Tbl. 1:	Stickers on the product	8
Tbl. 2:	Abbreviations used in this document	9
Tbl. 3:	Limits of use of the product	15
Tbl. 4:	Features of the rotary vane pumps	20
Tbl. 5:	Technical data / temperature switches	27
Tbl. 6:	Requirements on the cooling water composition	28
Tbl. 7:	Motor protection switch settings for Hena 401 global motor	32
Tbl. 8:	Motor protection switch settings for Hena 401 Asian motor	32
Tbl. 9:	Motor protection switch settings for Hena 631 global motor	32
Tbl. 10:	Motor protection switch settings for Hena 631 Asian motor	32
Tbl. 11:	Maintenance intervals	40
Tbl. 12:	Troubleshooting for rotary vane pumps	54
Tbl. 13:	Spare parts packages	57
Tbl. 14:	Consumables	57
Tbl. 15:	Accessories	59
Tbl. 16:	Conversion table: Pressure units	60
Tbl. 17:	Conversion table: Units for gas throughput	60
Tbl. 18:	Hena 401 with air cooling	61
Tbl. 19:	Hena 401 with water cooling	62
Tbl. 20:	Hena 631 with air cooling	63
Tbl. 21:	Hena 631 with water cooling	64



List of figures

Fig. 1:	Position of the stickers on the product	9
Fig. 2:	Operating principle	18
Fig. 3:	Structure of the rotary vane pump	18
Fig. 4:	Transporting the vacuum pump	22
Fig. 5:	Top view of the minimum distances to the lateral limitations	23
Fig. 6:	Filling the operating fluid	26
Fig. 7:	Thermal circuit breaker for exhaust gas temperature monitoring	27
Fig. 8:	Connection data for the thermal circuit breaker	27
Fig. 9:	Making the cooling water connection	29
Fig. 10:	Delta connection	30
Fig. 11:	Star circuit	30
Fig. 12:	Double star circuit	31
Fig. 13:	Delta connection	31
Fig. 14:	Star circuit	31
Fig. 15:	Connection example with PTC thermistor tripping unit	33
Fig. 16:	Gas ballast valve	36
Fig. 17:	Refilling operating fluid	37
Fig. 18:	Draining the operating fluid	43
Fig. 19:	Changing the operating fluid filter	44
Fig. 20:	Dismantling the exhaust filters	45
Fig. 21:	Mounting the exhaust filters	46
Fig. 22:	Dismantling / assembling the intake strainer	47
Fig. 23:	Cleaning the gas ballast filter	48
Fig. 24:	Operating fluid return with float valve	49
Fig. 25:	Dimensions Hena 401 with air cooling Three phase motor IE3	65
Fig. 26:	Dimensions Hena 401 S with water cooling Three phase motor IE3	66
Fig. 27:	Dimensions Hena 631 with air cooling Three phase motor IE3	67
Fig. 28:	Dimensions Hena 631 S with water cooling Three phase motor IE3	68



1 About this manual



IMPORTANT

Read carefully before use.
Keep the manual for future consultation.

1.1 Validity

This operating instructions is a customer document of Pfeiffer Vacuum. The operating instructions describe the functions of the named product and provide the most important information for the safe use of the device. The description is written in accordance with the valid directives. The information in this operating instructions refers to the product's current development status. The document shall remain valid provided that the customer does not make any changes to the product.

1.1.1 Applicable documents

Document	Number
"Hena K" supplementary information	PD0109EI
Declaration of conformity	A component of these instructions

You can find this document in the [Pfeiffer Vacuum Download Center](#).

1.1.2 Variants

These instructions apply to HenaLine vacuum pumps.

Pump type	Pump version
Hena 401	Standard version of rotary vane pump
Hena 631	Standard version of rotary vane pump
Hena 401 K	Rotary vane pump with base frame and intake flange
Hena 631 K	Rotary vane pump with base frame and intake flange

1.2 Target group

This operating instructions is intended for persons who

- transport,
- installation,
- operate,
- decommissioning,
- servicing and cleaning,
- storage or disposal.

The work described in this document may only be carried out by persons who have appropriate professional qualifications (experts).

1.3 Conventions

1.3.1 Instructions in the text

Usage instructions in the document follow a general structure that is complete in itself. The required action is indicated by an individual step or multi-part action steps.

Individual action step

A horizontal, solid triangle indicates the only step in an action.

- ▶ This is an individual action step.

Sequence of multi-part action steps

The numerical list indicates an action with multiple necessary steps.

1. Step 1
2. Step 2
3. ...

1.3.2 Pictographs

Pictographs used in the document indicate useful information.



Note



Tip

1.3.3 Stickers on the product

This section describes all the stickers on the product along with their meanings.

	<p>Rating plate (example) Rating plate of the rotary vane vacuum pump</p>
	<p>Motor rating plate Rating plate of the motor</p>
	<p>Warning hot surface This sticker warns of injuries caused by high temperatures as a result of contact without protection during operation.</p>
	<p>Operating instructions note This sticker indicates that this operating instructions must be read before performing any tasks.</p>
	<p>Arrow indicating direction of rotation The direction of rotation arrow indicates the required motor rotation direction.</p>

Tbl. 1: Stickers on the product



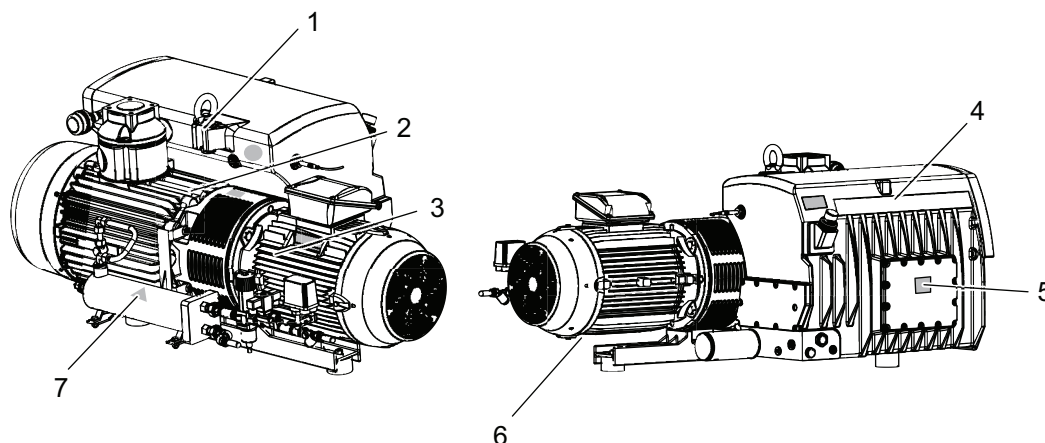

Fig. 1: Position of the stickers on the product

- | | | | |
|---|---|---|--|
| 1 | Operating instructions note | 5 | Hot surface warning sign |
| 2 | Hot surface warning sign | 6 | Arrow indicating direction of rotation |
| 3 | Rating plate of the motor | 7 | Hot surface warning sign |
| 4 | Rating plate of the rotary vane vacuum pump | | |

1.3.4 Abbreviations

Abbreviation	Meaning in this document
BA	Operating instructions
ID	Internal diameter
IE3	Efficiency of the electric motors (premium efficiency class)
N.N.	Mean sea level
PE	Earthed conductor (protective earth)
PTC	Temperature-dependent resistor (positive temperature coefficient)
PVC	Polyvinyl chloride (PVC)
WAF	width across flats
RSSR	Radial shaft seal ring
MM	Maintenance manual

Tbl. 2: Abbreviations used in this document

1.4 Trademark proof

- Loctite® is a trademark of HENKEL IP & HOLDING GMBH.

2 Safety

2.1 General safety information

The following 4 risk levels and 1 information level are taken into account in this document.

⚠ DANGER	
<p>Immediately pending danger Indicates an immediately pending danger that will result in death or serious injury if not observed.</p> <ul style="list-style-type: none"> ▶ Instructions to avoid the danger situation 	
⚠ WARNING	
<p>Potential pending danger Indicates a pending danger that could result in death or serious injury if not observed.</p> <ul style="list-style-type: none"> ▶ Instructions to avoid the danger situation 	
⚠ CAUTION	
<p>Potential pending danger Indicates a pending danger that could result in minor injuries if not observed.</p> <ul style="list-style-type: none"> ▶ Instructions to avoid the danger situation 	
NOTICE	
<p>Danger of damage to property Is used to highlight actions that are not associated with personal injury.</p> <ul style="list-style-type: none"> ▶ Instructions to avoid damage to property 	
<div style="border: 1px solid black; padding: 5px; display: inline-block;">  </div>	Notes, tips or examples indicate important information about the product or about this document.

2.2 Safety instructions

All safety instructions in this document are based on the results of the risk assessment carried out in accordance with Machinery Directive 2006/42/EC Annex I and DIN EN ISO 12100 Section 5. Where applicable, all life cycle phases of the product were taken into account.

Risks during transport

⚠ WARNING
<p>Risk of serious injury from swinging, toppling or falling objects During transport, there is a risk of crushing and impact on swinging, toppling or falling objects. There is a risk of injuries to limbs, up to and including bone fractures and head injuries.</p> <ul style="list-style-type: none"> ▶ Secure the danger zone if necessary. ▶ Pay attention to the center of gravity of the load during transport. ▶ Ensure even movements and moderate speeds. ▶ Observe safe handling of the transport devices. ▶ Avoid sloping attachment aids. ▶ Never stack products. ▶ Wear protective equipment, e.g. safety shoes.



Risks during installation

⚠ DANGER**Danger to life from electric shock**

Touching exposed and voltage-bearing elements causes an electric shock. Improper connection of the mains supply leads to the risk of touchable live housing parts. There is a risk to life.

- ▶ Before the installation, check that the connection leads are voltage-free.
- ▶ Make sure that electrical installations are only carried out by qualified electricians.
- ▶ Provide adequate grounding for the device.
- ▶ After connection work, carry out an earthed conductor check.

⚠ WARNING**Danger of poisoning due to toxic process media escaping from the exhaust pipe**

During operation with no exhaust line, the vacuum pump allows exhaust gases and vapors to escape freely into the air. There is a risk of injury and fatality due to poisoning in processes with toxic process media.

- ▶ Observe the pertinent regulations for handling toxic process media.
- ▶ Safely purge toxic process media via an exhaust line.
- ▶ Use appropriate filter equipment to separate toxic process media.

⚠ WARNING**Tilting danger! Serious injury due to tilting of the product**

There is a danger of the vacuum pump not attached tipping over due to changes in the center of gravity or incorrect loading. Serious injuries due to trapping or crushing of limbs, e.g. feet, are the result.

- ▶ Do not use the vacuum pump as a climbing aid.
- ▶ Do not exert any force on the product.
- ▶ Ensure that the product has a safe centre of gravity, when mounting components.
- ▶ Wear protective equipment, e.g. protective shoes

⚠ CAUTION**Danger of injury from moving parts**

After a power failure or a standstill as a result of overheating, the motor restarts automatically. There is a risk of injury to fingers and hands if they enter the operating range of rotating parts.

- ▶ Safely disconnect motor from the mains.
- ▶ Secure the motor against reactivation.
- ▶ Dismantle the vacuum pump for inspection, away from the system if necessary.

⚠ CAUTION**Danger of injury from bursting as a result of high pressure in the exhaust line**

Faulty or inadequate exhaust pipes lead to dangerous situations, e.g. increased exhaust pressure. There is a danger of bursting. Injuries caused by flying fragments, the escaping of high pressure, and damage to the unit cannot be excluded.

- ▶ Route the exhaust line without shut-off units.
- ▶ Observe the permissible pressures and pressure differentials for the product.
- ▶ Check the function of the exhaust line on a regular basis.



Risks during operation

⚠ WARNING

Danger of poisoning due to toxic process media escaping from the exhaust pipe

During operation with no exhaust line, the vacuum pump allows exhaust gases and vapors to escape freely into the air. There is a risk of injury and fatality due to poisoning in processes with toxic process media.

- ▶ Observe the pertinent regulations for handling toxic process media.
- ▶ Safely purge toxic process media via an exhaust line.
- ▶ Use appropriate filter equipment to separate toxic process media.

⚠ WARNING

Risk of burns from ejected hot oil mist

During operation, hot pressurized oil mist escapes from the operating fluid separator.

- ▶ Only operate the vacuum pump with the filler screw securely fitted.
- ▶ Open the locking screws on the separator only while the vacuum pump is switched off.

⚠ WARNING

Tilting danger! Serious injury due to tilting of the product

There is a danger of the vacuum pump not attached tipping over due to changes in the center of gravity or incorrect loading. Serious injuries due to trapping or crushing of limbs, e.g. feet, are the result.

- ▶ Do not use the vacuum pump as a climbing aid.
- ▶ Do not exert any force on the product.
- ▶ Ensure that the product has a safe centre of gravity, when mounting components.
- ▶ Wear protective equipment , e.g. protective shoes

⚠ CAUTION

Risk of injury from entrapment of body parts

After a power failure or a standstill as a result of overheating, the motor restarts automatically. A risk exists of minor injury to fingers and hands (e.g., hematoma), from direct contact with the vacuum flange.

- ▶ Maintain sufficient distance to the vacuum flange during all work.
- ▶ Safely disconnect motor from the mains.
- ▶ Secure the motor against re-start.

⚠ CAUTION

Danger of injury from bursting as a result of high pressure in the exhaust line

Faulty or inadequate exhaust pipes lead to dangerous situations, e.g. increased exhaust pressure. There is a danger of bursting. Injuries caused by flying fragments, the escaping of high pressure, and damage to the unit cannot be excluded.

- ▶ Route the exhaust line without shut-off units.
- ▶ Observe the permissible pressures and pressure differentials for the product.
- ▶ Check the function of the exhaust line on a regular basis.

⚠ CAUTION

Danger of burns on hot surfaces

Depending on the operating and ambient conditions, the surface temperature of the vacuum pump can increase to above 70 °C.

- ▶ Provide suitable touch protection.



Risks during maintenance, decommissioning and malfunctions

⚠ WARNING**Health hazard through poisoning from toxic contaminated components or devices**

Toxic process media result in contamination of devices or parts of them. During maintenance work, there is a risk to health from contact with these poisonous substances. Illegal disposal of toxic substances causes environmental damage.

- ▶ Take suitable safety precautions and prevent health hazards or environmental pollution by toxic process media.
- ▶ Decontaminate affected parts before carrying out maintenance work.
- ▶ Wear protective equipment.

⚠ WARNING**Danger to life from electric shock in the event of a fault**

In the event of a fault, devices connected to the mains may be live. There is a danger to life from electric shock when making contact with live components.

- ▶ Always keep the mains connection freely accessible so you can disconnect it at any time.

⚠ WARNING**Health hazard and risk of environmental damage from toxic contaminated operating fluid**

Toxic process media can cause operating fluid contamination. When changing the operating fluid, there is a health hazard due to contact with poisonous substances. Illegal disposal of toxic substances causes environmental damage.

- ▶ Wear suitable personal protective equipment when handling these media.
- ▶ Dispose of the operating fluid according to locally applicable regulations.

⚠ WARNING**Health hazard through poisoning from toxic contaminated components or devices**

Toxic process media result in contamination of devices or parts of them. During maintenance work, there is a risk to health from contact with these poisonous substances. Illegal disposal of toxic substances causes environmental damage.

- ▶ Take suitable safety precautions and prevent health hazards or environmental pollution by toxic process media.
- ▶ Decontaminate affected parts before carrying out maintenance work.
- ▶ Wear protective equipment.

⚠ WARNING**Tilting danger! Serious injury due to tilting of the product**

There is a danger of the vacuum pump not attached tipping over due to changes in the center of gravity or incorrect loading. Serious injuries due to trapping or crushing of limbs, e.g. feet, are the result.

- ▶ Do not use the vacuum pump as a climbing aid.
- ▶ Do not exert any force on the product.
- ▶ Ensure that the product has a safe centre of gravity, when mounting components.
- ▶ Wear protective equipment, e.g. protective shoes

⚠ CAUTION**Risk of injury from entrapment of body parts**

After a power failure or a standstill as a result of overheating, the motor restarts automatically. A risk exists of minor injury to fingers and hands (e.g., hematoma), from direct contact with the vacuum flange.

- ▶ Maintain sufficient distance to the vacuum flange during all work.
- ▶ Safely disconnect motor from the mains.
- ▶ Secure the motor against re-start.



⚠ CAUTION

Scalding from hot operating fluid

Danger of burns when draining operating fluid if it comes into contact with the skin.

- ▶ Wear protective equipment.
- ▶ Use a suitable collection receptacle.

⚠ CAUTION

Danger of burns on hot surfaces

In the event of a fault, the surface temperature of the vacuum pump can increase to above 105 °C.

- ▶ Allow the vacuum pump to cool down before carrying out any work.
- ▶ Wear personal protective equipment if necessary.

⚠ CAUTION

Danger of injury from moving parts

After a power failure or a standstill as a result of overheating, the motor restarts automatically. There is a risk of injury to fingers and hands if they enter the operating range of rotating parts.

- ▶ Safely disconnect motor from the mains.
- ▶ Secure the motor against reactivation.
- ▶ Dismantle the vacuum pump for inspection, away from the system if necessary.

Risks during disposal

⚠ WARNING

Health hazard through poisoning from toxic contaminated components or devices

Toxic process media result in contamination of devices or parts of them. During maintenance work, there is a risk to health from contact with these poisonous substances. Illegal disposal of toxic substances causes environmental damage.

- ▶ Take suitable safety precautions and prevent health hazards or environmental pollution by toxic process media.
- ▶ Decontaminate affected parts before carrying out maintenance work.
- ▶ Wear protective equipment.

2.3 Safety precautions

i

Duty to provide information on potential dangers

The product holder or user is obliged to make all operating personnel aware of dangers posed by this product.

Every person who is involved in the installation, operation or maintenance of the product must read, understand and adhere to the safety-related parts of this document.

i

Infringement of conformity due to modifications to the product

The Declaration of Conformity from the manufacturer is no longer valid if the operator changes the original product or installs additional equipment.

- Following the installation into a system, the operator is required to check and re-evaluate the conformity of the overall system in the context of the relevant European Directives, before commissioning that system.

General safety precautions when handling the product

- ▶ Observe all applicable safety and accident prevention regulations.
- ▶ Check that all safety measures are observed at regular intervals.
- ▶ Do not expose body parts to the vacuum.
- ▶ Always ensure a secure connection to the earthed conductor (PE).
- ▶ Never disconnect plug connections during operation.
- ▶ Observe the above shutdown procedures.



- ▶ Keep lines and cables away from hot surfaces ($> 70\text{ °C}$).
- ▶ Never fill or operate the unit with cleaning agents or cleaning agent residues.
- ▶ Do not carry out your own conversions or modifications on the unit.
- ▶ Observe the unit protection class prior to installation or operation in other environments.
- ▶ Provide suitable touch protection, if the surface temperature exceeds 70 °C .

2.4 Limits of use of the product

Parameter	Hena 401, Hena 631
Installation location	<ul style="list-style-type: none"> • Indoors, protected against: <ul style="list-style-type: none"> – dust deposits – falling objects – fire-fighting water • Outdoors, protected against: <ul style="list-style-type: none"> – falling objects – direct influence of weather such as rain, splash water, strong drafts and sunlight – fire-fighting water – lightning strike
Installation altitude	max. 1000 m above sea level At installation heights $> 1000\text{ m}$ above sea level, the rated power of the motor must be reduced or the ambient temperature limited due to increased heating of the vacuum pump.
Orientation	Horizontal
permissible angle of inclination	$\pm 1\text{ °}$
Ambient temperature with mineral-based operating fluids (P3)	5 °C to $+35\text{ °C}$
Ambient temperature with synthetic-based operating fluids (D1)	$+5\text{ °C}$ to $+40\text{ °C}$
Relative air humidity	max. 85%
Pumped medium intake temperature, max.	$+80\text{ °C}$
Permissible operating pressure range during continuous operation	$< 800\text{ hPa}$
Exhaust pressure	Atmospheric pressure

Tbl. 3: Limits of use of the product

2.5 Proper use

- ▶ Use the vacuum pump for vacuum generation only.
- ▶ Use the vacuum pump only for pumping clean air or other non-aggressive, non-poisonous and non-explosive gases.
- ▶ Convey media with a greater density than air only after prior consultation with Pfeiffer Vacuum. Avoid high thermal and mechanical loading of the rotary vane pump and the drive.
- ▶ When pumping media with an oxygen concentration level of $\geq 21\%$, only use perfluorinated, synthetic oils (F4, F5, A113) as operating fluid.
- ▶ Adhere to the installation, commissioning, operating, and maintenance instructions.
- ▶ Do not use any accessory parts other than those recommended by Pfeiffer Vacuum.

2.6 Foreseeable improper use

Improper use of the product invalidates all warranty and liability claims. Any use that is counter to the purpose of the product, whether intentional or unintentional, is regarded as misuse, in particular:

- Pumping of corrosive media
- Pumping radioactive media

- Pumping of gases that introduce an ignition source to the suction chamber
- Pumping of gases that contain impurities such as particles, dust, or condensate
- Pumping of explosive media
- Pumping of media with a propensity to sublimation
- Pumping of fluids
- Use of the vacuum pump in potentially explosive atmospheres
- Use of the vacuum pump outside the specified area of application
- Use for pressure generation
- Use in strong electrical, magnetic, or electromagnetic fields
- Connection to vacuum pumps or equipment which are not suitable for this purpose according to their operating instructions
- Connection to devices with exposed live parts
- Use of accessories or spare parts not listed in these operating instructions
- Use of operating fluids other than those specified by Pfeiffer Vacuum
- Use of D1 or mineral oil as operating fluid with an oxygen concentration level of > 21 %. Mineral oils are combustible and ignite in high temperatures and when they come into contact with pure oxygen. This oils oxidize heavily and thus lose their lubricating capacity.

2.7 Personnel qualification

The work described in this document may only be carried out by persons who have appropriate professional qualifications and the necessary experience.

Training people

1. Train the technical personnel on the product.
2. Only let personnel to be trained work with and on the product when under the supervision of trained personnel.
3. Only allow trained technical personnel to work with the product.
4. Before starting work, make sure that the commissioned personnel have read and understood these operating instructions and all applicable documents, in particular the safety, maintenance and repair information.

2.7.1 Ensuring personnel qualification

Specialist for mechanical work

Only a trained specialist may carry out mechanical work. Within the meaning of this document, specialists are people responsible for construction, mechanical installation, troubleshooting, and maintenance of the product, and who have the following qualifications:

- Qualification in the mechanical field in accordance with nationally applicable regulations
- Knowledge of this documentation

Specialist for electrical engineering work

Only a trained electrician may carry out electrical engineering work. Within the meaning of this document, electricians are people responsible for electrical installation, commissioning, troubleshooting, and maintenance of the product, and who have the following qualifications:

- Qualification in the electrical engineering field in accordance with nationally applicable regulations
- Knowledge of this documentation

In addition, these individuals must be familiar with applicable safety regulations and laws, as well as the other standards, guidelines, and laws referred to in this documentation. The above individuals must have expressly granted operational authorization, to commission, program, configure, mark, and earth devices, systems, and circuits in accordance with safety technology standards.

Trained individuals

Only adequately trained individuals may carry out all works in other transport, storage, operation, and disposal fields. Such training must ensure that individuals are capable of carrying out the required activities and work steps safely and properly.

2.7.2 Personnel qualification for maintenance and repair

Adequately trained individuals are:



- **Maintenance level 1**
 - Customer with technical education
 - Pfeiffer Vacuum service technician
- **Maintenance level 3**
 - Pfeiffer Vacuum service technician

3 Product description

3.1 Function

The rotary vane pumps of the HenaLine are single-stage, oil-sealed rotary positive displacement pumps with air cooling and circulatory lubrication. A non-return valve in the vacuum connection closes the intake line automatically when the rotary vane pump is switched off and prevents an operating fluid return flow. The integrated oil mist filter cleans the conveyed gas and prevents the operating fluid mist from being emitted at the exhaust. The operating fluid collected in the separator is supplied back to the rotary vane pump. An operating fluid filter is also installed for cleaning the operating fluid.

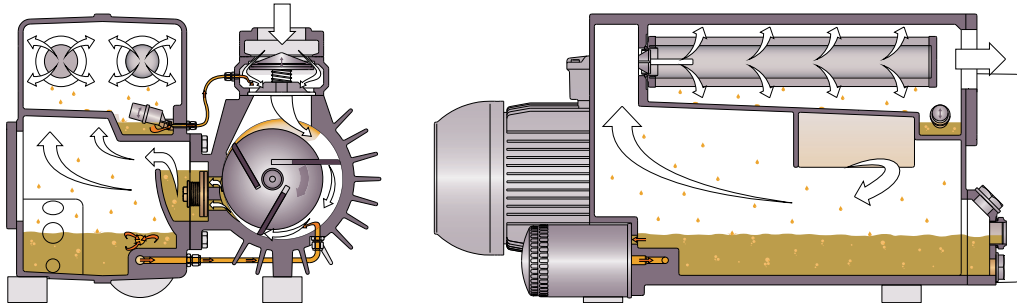

Fig. 2: Operating principle

The pumping system is made up of the housing, the eccentrically mounted rotor, and the centrifugally sliding vanes, which divide the suction chamber into multiple chambers. The volume of each chamber changes periodically as the rotor rotates. This causes the gas to be continuously drawn in at the vacuum connection and compressed in the suction chamber by the rotation of the rotor until the exhaust valve opens against the atmospheric pressure and the gas leaves the suction chamber.

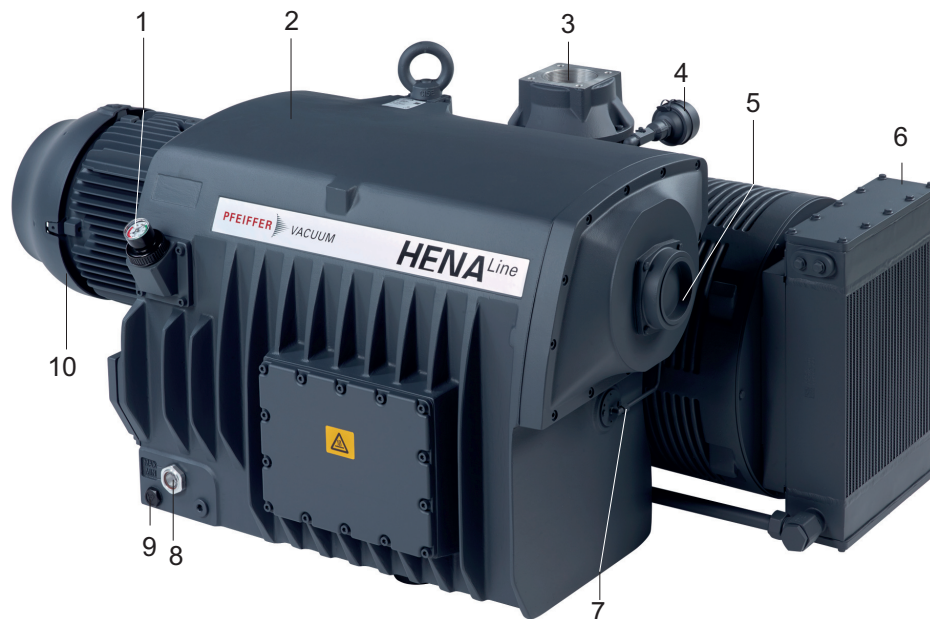

Fig. 3: Structure of the rotary vane pump

- | | |
|-------------------------------|--------------------------|
| 1 Filler screw with manometer | 6 Oil/air heat exchanger |
| 2 Operating fluid separator | 7 Float valve |
| 3 Vacuum connection | 8 Sight glass |
| 4 Gas ballast filter | 9 Drain screw |
| 5 Exhaust connection | 10 Motor |

3.1.1 Operating fluid

The pump oil, also known as operating fluid, fulfills various tasks in a rotary vane pump:



- lubrication of all moving parts
- filling part of the dead volume under the exhaust valve
- sealing the gap between the intake and exhaust channel, and between the vanes and the working chamber
- ensuring an optimal temperature balance through heat transfer

3.1.2 Cooling

The rotary vane pump is cooled by thermal radiation from its surface, the air current from the two fans and the pumped gas.

In case of thermally unfavorable ambient conditions, Pfeiffer Vacuum recommends the use of a pump version with oil/water heat exchanger.

- Air cooling (standard)
- Oil/water heat exchanger (optional)

3.1.3 Gas ballast system

The gas ballast system supplies air to the working chamber of the rotary vane pump periodically at the beginning of the compression phase. When pumping down vapors, this air prevents condensation within certain limits in the rotary vane pump. The gas ballast valve affects the final pressure of the rotary vane pump.

3.1.4 Operating fluid return via the float valve



Function of the operating fluid return

The operating fluid return functions only at an operating pressure of < 800 hPa.

The rotary vane pump is equipped with an operating fluid return as standard. If the operating fluid collected in the operating fluid separator reaches a certain level, a float valve opens and the ejected operating fluid is returned to the intake port of the vacuum pump.

3.2 Identifying the product

- ▶ To ensure clear identification of the product when communicating with Pfeiffer Vacuum, always keep all of the information on the rating plate to hand.
- ▶ Observe the motor-specific data on the motor rating plate attached separately.

3.3 Product features

Pump type	Characteristics
Hena 401	<ul style="list-style-type: none"> • Nominal pumping speed <ul style="list-style-type: none"> – 50 Hz: 410 m³/h – 60 Hz: 480 m³/h • Vacuum connection and gas outlet: G 3" • Operating fluid return via the float valve • Gas ballast unit with shut-off valve • Oil/water heat exchanger (optional)
Hena 401 K	As per Hena 401, in addition with: <ul style="list-style-type: none"> • Intake flange DN 160 ISO-F for direct assembly of a roots pump • Base frame

Pump type	Characteristics
Hena 631	<ul style="list-style-type: none"> • Nominal pumping speed <ul style="list-style-type: none"> – 50 Hz: 630 m³/h – 60 Hz: 760 m³/h • Vacuum connection and gas outlet: G 3" • Operating fluid return via the float valve • Gas ballast unit with shut-off valve • Oil/water heat exchanger (optional)
Hena 631 K	As per Hena 634, in addition with: <ul style="list-style-type: none"> • Intake flange DN 160 ISO-F for direct assembly of a roots pump • Base frame

Tbl. 4: Features of the rotary vane pumps

3.4 Scope of delivery

- Rotary vane vacuum pump with motor
- Operating fluid
- Locking caps for vacuum and exhaust connection
- Operating instructions



4 Transportation and Storage

4.1 Transport

WARNING

Risk of serious injury from swinging, toppling or falling objects

During transport, there is a risk of crushing and impact on swinging, toppling or falling objects. There is a risk of injuries to limbs, up to and including bone fractures and head injuries.

- ▶ Secure the danger zone if necessary.
- ▶ Pay attention to the center of gravity of the load during transport.
- ▶ Ensure even movements and moderate speeds.
- ▶ Observe safe handling of the transport devices.
- ▶ Avoid sloping attachment aids.
- ▶ Never stack products.
- ▶ Wear protective equipment, e.g. safety shoes.

NOTICE

Equipment damage from operating fluid leaking into the pumping system.

If the vacuum pump is tipped, the operating fluid will overflow into the pumping system, resulting in the vane breaking when the vacuum pump is switched on.

- ▶ Always transport the vacuum pump horizontally or without operating fluid filling.
- ▶ Fill in the operating fluid only at the final installation location.



Preparations for transport

Pfeiffer Vacuum recommends keeping the transport packaging and original protective cover.

General information regarding safe transport

1. Observe the weight specified on packaging.
2. Use personal protective equipment, e.g. safety shoes.
3. Use transport equipment (e.g. fork lift truck or lift truck).
4. Where possible, always transport or ship the product in the original packaging.
5. Be mindful of transport damage.
6. Always place the product on an adequately sized, level surface.

Transporting the vacuum pump with its packaging

1. Observe safe handling of manually operated transport devices.
2. Note the center of gravity of the load.
3. Use a fork lift truck or pallet truck to transport the vacuum pump on a pallet in its packaging.
4. Ensure harmonious movements and moderate speeds.
5. To protect the inside of the pump, leave both protective covers on the connections during transport.



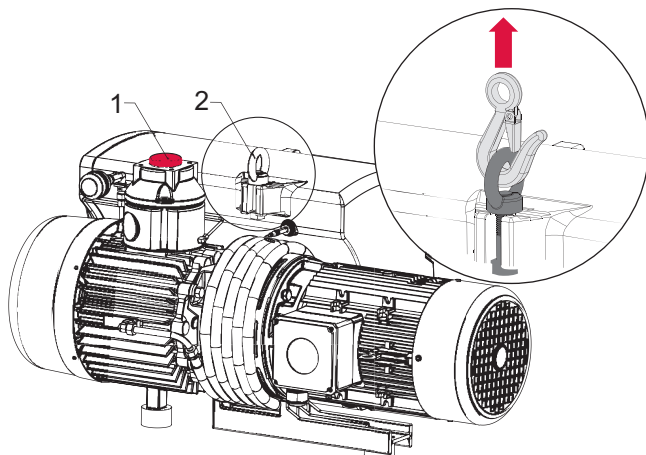

Fig. 4: Transporting the vacuum pump

- 1 Protective cap
- 2 Crane lug

Transporting the vacuum pump without its packaging

1. Unpack the vacuum pump.
2. To protect the inside of the pump, leave the protective caps on the connections during transport.
3. For lifting, use the crane lug provided for this purpose, located on the top of the pump.
4. Lift the vacuum pump out of the transport packaging.
5. Always place the vacuum pump on an adequately sized, level surface.

4.2 Storing the vacuum pump



Storage

Pfeiffer Vacuum recommends storing the products in their original transport packaging.

Procedure

1. Seal the vacuum and exhaust connection.
2. Make sure that the gas ballast valve is closed.
3. Store the vacuum pump only in dry, dust-free rooms, within the specified ambient conditions.
4. In rooms with humid or aggressive atmospheres: Hermetically seal the vacuum pump together with a drying agent in a plastic bag.
5. Change the operating fluid if the storage period is longer than 2 years.



5 Installation

5.1 Setting up the vacuum pump

⚠ WARNING

Tilting danger! Serious injury due to tilting of the product

There is a danger of the vacuum pump not attached tipping over due to changes in the center of gravity or incorrect loading. Serious injuries due to trapping or crushing of limbs, e.g. feet, are the result.

- ▶ Do not use the vacuum pump as a climbing aid.
- ▶ Do not exert any force on the product.
- ▶ Ensure that the product has a safe centre of gravity, when mounting components.
- ▶ Wear protective equipment, e.g. protective shoes

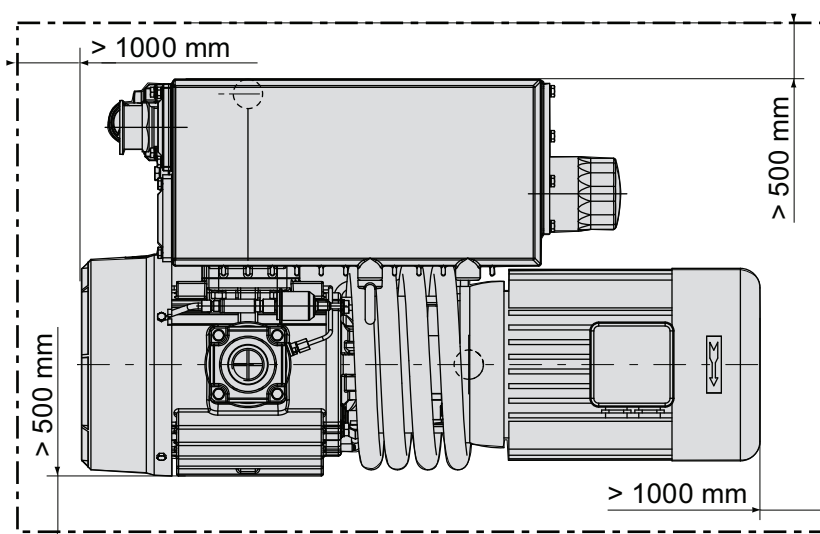

Fig. 5: Top view of the minimum distances to the lateral limitations

Procedure

1. Place the vacuum pump on a flat, horizontal surface, to safeguard the operating fluid supply.
2. Observe the permissible angle of inclination of $\pm 1^\circ$.
3. Screw the vacuum pump onto the rubber-metal buffers on the mounting surface.
4. When installing the pump in a closed housing, ensure adequate air circulation.
5. Keep the sight glass and gas ballast valve visible and freely accessible.
6. Keep the voltage and frequency specifications on the motor rating plate visible and freely accessible.

5.2 Connecting the vacuum side

NOTICE

Property damage from contaminated gases

Pumping down gases that contain impurities (condensate, particles) damages the vacuum pump.

- ▶ Use suitable filters or separators from the Pfeiffer Vacuum range of accessories, to protect the vacuum pump.





Installation and operation of accessories

Pfeiffer Vacuum offers a series of special, compatible accessories for its rotary vane pumps.

- You can find information and ordering options for approved [accessories](#) online.
- Described accessories are not included in the shipment.

Required consumable material

- Screw lock, e.g. Loctite 245 or Loctite 577

Procedure

1. Remove the protective cover from the vacuum connection.
2. Establish the shortest possible pipeline between vacuum pump and vacuum chamber.
3. Choose a minimum diameter equal to the nominal diameter of the vacuum connection.
4. Clean the connection threads.
5. Seal the connection threads with screw lock.
6. Install the piping with pipe components and fasteners from the [Pfeiffer Vacuum Components Shop](#).
7. Support or suspend the piping to the vacuum pump so that no piping system forces act on the vacuum pump.
8. Use a screwing flange, separator or filter from the Pfeiffer Vacuum line of [accessories](#) if necessary.

5.3 Connecting the exhaust side

⚠ WARNING

Danger of poisoning due to toxic process media escaping from the exhaust pipe

During operation with no exhaust line, the vacuum pump allows exhaust gases and vapors to escape freely into the air. There is a risk of injury and fatality due to poisoning in processes with toxic process media.

- ▶ Observe the pertinent regulations for handling toxic process media.
- ▶ Safely purge toxic process media via an exhaust line.
- ▶ Use appropriate filter equipment to separate toxic process media.

⚠ CAUTION

Danger of injury from bursting as a result of high pressure in the exhaust line

Faulty or inadequate exhaust pipes lead to dangerous situations, e.g. increased exhaust pressure. There is a danger of bursting. Injuries caused by flying fragments, the escaping of high pressure, and damage to the unit cannot be excluded.

- ▶ Route the exhaust line without shut-off units.
- ▶ Observe the permissible pressures and pressure differentials for the product.
- ▶ Check the function of the exhaust line on a regular basis.



Installation and operation of accessories

Pfeiffer Vacuum offers a series of special, compatible accessories for its rotary vane pumps.

- You can find information and ordering options for approved [accessories](#) online.
- Described accessories are not included in the shipment.



Condensate separator

Pfeiffer Vacuum recommends installing a condensate separator, with condensate drain at the lowest point of the exhaust line.

Required consumable material

- Screw lock, e.g. Loctite 245 or Loctite 577



Procedure

1. Remove the protective cap from the exhaust connection.
2. Choose a minimum diameter equal to the nominal diameter of the exhaust connection.
3. Route the piping downwards from the vacuum pump, to prevent condensate return.
 - If an air trap is created in the system then a device for draining condensation water must be provided at the lowest point.
4. Clean the connection threads.
5. Seal the connection threads with screw lock.
6. Install the piping with pipe components and fasteners from the [Pfeiffer Vacuum Components Shop](#).
7. Support or suspend the piping to the vacuum pump so that no piping system forces act on the vacuum pump.

5.4 Filling the operating fluid

NOTICE**Risk of damage due to the use of non-approved operating fluid**

Product-specific performance data are not achieved. All liability and warranty claims against Pfeiffer Vacuum are also excluded.

- ▶ Only use approved operating fluids.
- ▶ Only use other application-specific operating fluids after consultation with Pfeiffer Vacuum.

**Checking the fill level**

The correct fill level is between the MIN/MAX markings or within the ring mark on the sight glass.

The type of operating fluid specified, as well as the filling quantity for the entire rotary vane vacuum pump, are shown on the rating plate. Only the operating fluid used during initial installation is permissible.

Approved operating fluid

- P3 (standard operating fluid)
- D1 for special applications (such as higher operating temperatures)

Required consumables

- Operating fluid

Required tool

- Open-end wrench, **WAF 27**

Required aids

- Funnel (optional)

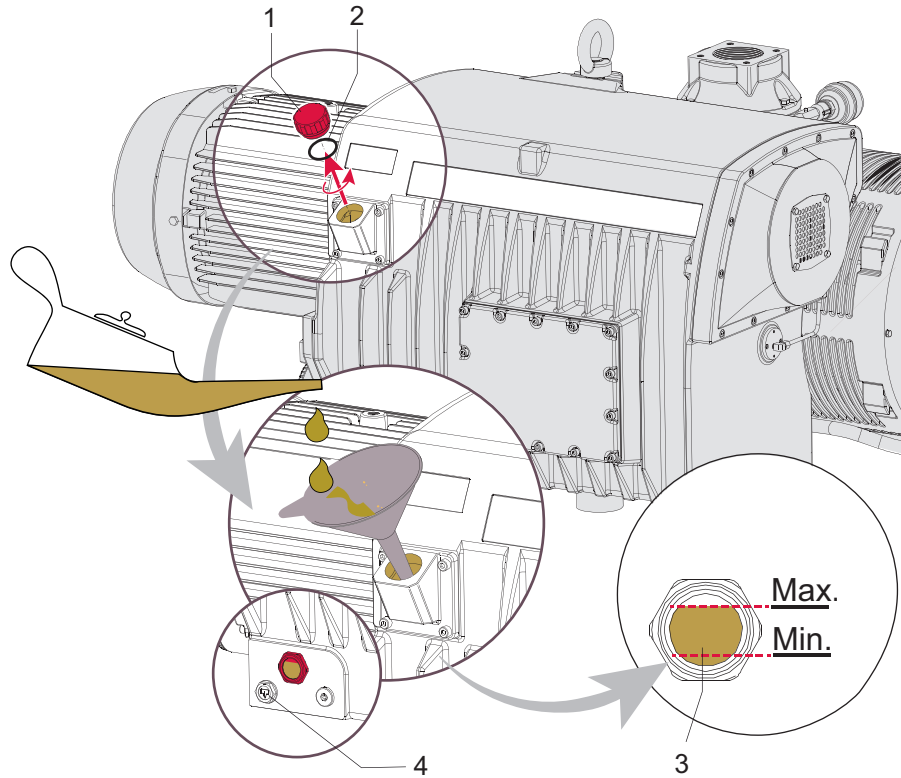

Fig. 6: Filling the operating fluid

- | | |
|-------------------------------|---------------|
| 1 Filler screw with manometer | 3 Sight glass |
| 2 O-ring | 4 Drain screw |

Filling the operating fluid

1. Unscrew the filler screw.
2. Fill the operating fluid according to the sight glass.
3. Screw in the filler screw.
 - Be careful with the O-ring.
4. Seal the vacuum connection.
5. Start the vacuum pump.
6. Operate the vacuum pump for approx. 5 minutes.
7. Switch off the vacuum pump.
8. Wait approx. 1 minute until the operating fluid has accumulated in the operating fluid separator.
9. Check the fill level.
10. If necessary, fill more operating fluid in case the fill level is incorrect.

5.5 Connect the exhaust gas temperature monitoring

A thermal circuit breaker on the oil mist filter monitors the gas temperature. The thermal circuit breaker is preset at the factory.



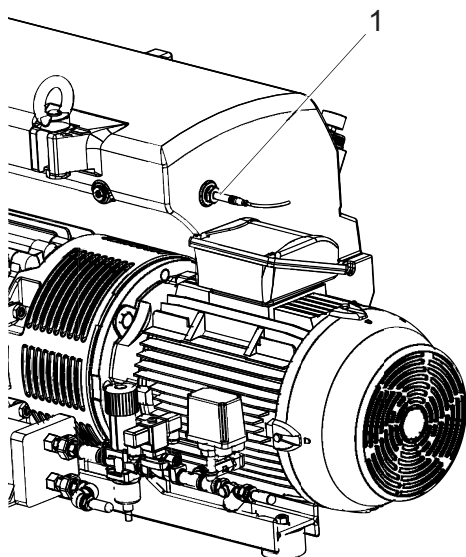

Fig. 7: Thermal circuit breaker for exhaust gas temperature monitoring

1 Thermal circuit breaker

Procedure

- ▶ Connect the electrical connection of the thermal circuit breaker such that an alarm is triggered and the vacuum pump shuts down when the gas temperature exceeds 110 °C.

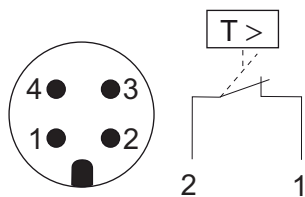

Fig. 8: Connection data for the thermal circuit breaker

- Pin 1 = Brown
- Pin 2 = White
- Pin 3= not connected
- Pin 4= not connected

Part number	PK 100 135 -T
Classification	Temperature Switch
Monitored Features	Exhaust gas temperature
For pump	Hena 400 – Hena 1600 Hena 401 Hena 631
Temperature: Operating	-12 – 130 °C
Connection	M12x1, 4-pin
Cable length	3 m
Set point: Temperature max.	110 °C
Accuracy: % of measurement	± 5 %
Switching voltage	90 – 230 V AC / 1 – 48 V DC
Current max.	1 A
Contact	Normally closed
Protection category	IP65

Tbl. 5: Technical data / temperature switches

5.6 Connecting the oil/water heat exchanger

For applications with thermally unfavorable ambient conditions, Pfeiffer Vacuum recommends the use of an optional oil/water heat exchanger. This is fitted at the factory and cannot be retrofitted later on.

The volume of cooling water can be regulated at the control valve in accordance with the operating conditions and cooling water temperature (position 0 => max. flow rate, Position 5 => min. flow rate).

Additional monitoring devices to be provided on site

- A solenoid valve for opening/closing the cooling water supply (stops the supply when the vacuum pump is switched off).
- A pressure switch for monitoring of the cooling water pressure.

NOTICE

Vacuum pump damage caused by different cooling characteristics

For applications with short switching cycles or increased ambient temperature, there is a risk of damaging the rotor after switching off temporarily.

- ▶ Always switch the oil / water cooling off together with the vacuum pump.
- ▶ For checking the cooling water flow, use a solenoid valve that only opens when the vacuum pump is switched on.

Parameter	Cooling water
Appearance	<ul style="list-style-type: none"> • filtered • mechanically clear • visually clear • no turbidity • no sediment • free from grease and oil
pH value	7 to 9
Carbonate hardness, max.	10 °dH 12.53 °e 17.8 °fH 178 ppm CaCO ₃
Chloride content, max.	100 mg/l.
Sulfate content, max.	240 mg/l.
Carbonic acid content, max.	not detectable
Ammonia content, max.	not detectable
Electrical conductivity, max.	500 µS/cm
Particle size, max.	150 µm
Cooling water temperature	5 – 35 °C
Cooling water flow	300 l/h
Feed line overpressure, max.	2000 – 6000 hPa

Tbl. 6: Requirements on the cooling water composition

Required material

- Cooling water hose, ID 19 mm
- Hose clamps



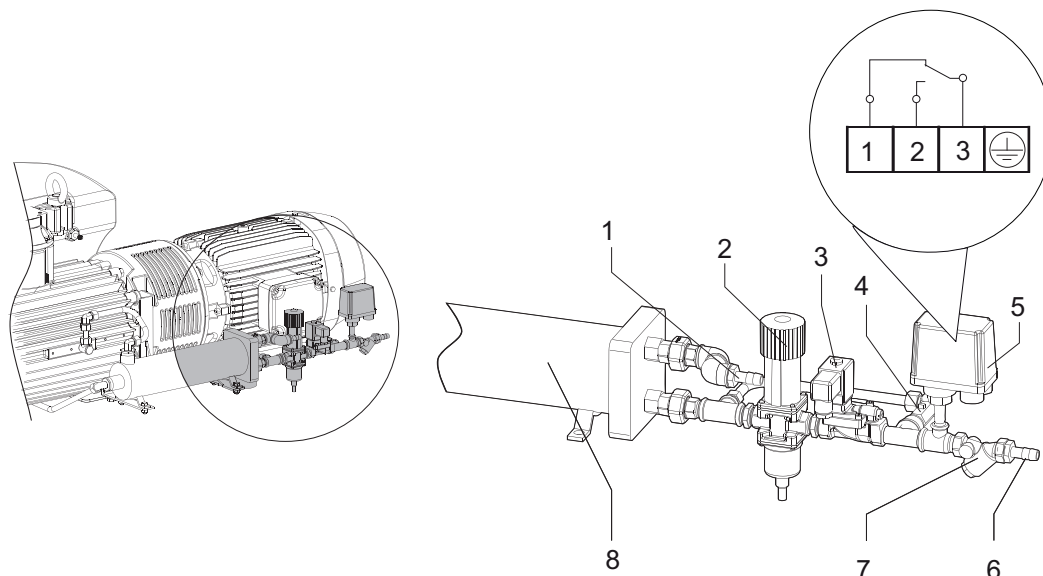

Fig. 9: Making the cooling water connection

- | | |
|-------------------------------|----------------------------|
| 1 Cooling water outlet | 5 Pressure switch |
| 2 Cooling water control valve | 6 Cooling water inlet |
| 3 Solenoid valve | 7 Water filter |
| 4 Ball valve (bypass valve) | 8 Oil/water heat exchanger |

Making the cooling water connection

1. Connect the cooling water lines:
 - Cooling water inlet
 - Cooling water outlet
2. Ensure that the outlet is unpressurized.
3. Open the influx.
4. Open the bypass valve and at the same time fill the cooling system until cooling water is emitted at the outlet.
5. Close the bypass valve.
6. If necessary, close the pressure switch and solenoid valve for monitoring and control of the cooling water flow as prescribed in the supplier's documentation.

5.7 Establishing mains connection

⚠ DANGER

Danger to life from electric shock

Touching exposed and voltage-bearing elements causes an electric shock. Improper connection of the mains supply leads to the risk of touchable live housing parts. There is a risk to life.

- ▶ Before the installation, check that the connection leads are voltage-free.
- ▶ Make sure that electrical installations are only carried out by qualified electricians.
- ▶ Provide adequate grounding for the device.
- ▶ After connection work, carry out an earthed conductor check.

⚠ CAUTION

Danger of injury from moving parts

After a power failure or a standstill as a result of overheating, the motor restarts automatically. There is a risk of injury to fingers and hands if they enter the operating range of rotating parts.

- ▶ Safely disconnect motor from the mains.
- ▶ Secure the motor against reactivation.
- ▶ Dismantle the vacuum pump for inspection, away from the system if necessary.

NOTICE

Risk of damage from excess voltage

Incorrect or excessive mains voltage will destroy the motor.

- ▶ Always observe the motor rating plate specifications.
- ▶ Route the mains connection in accordance with locally applicable provisions.
- ▶ Always provide a suitable mains fuse to protect the motor and supply cable in the event of a fault.
 - Pfeiffer Vacuum recommends the circuit breaker type "K" with slow tripping characteristic.

NOTICE

Property damage from high starting torque

The specific load behavior of the vacuum pump requires direct on-line starting at full motor power. Engine damage occurs if a different starting circuit is used.

- ▶ Always start the motor directly.
- ▶ **Never** use a star-delta start-up circuit.

5.7.1 Connect three phase motor with 6-pin terminal board

There are 2 different circuit configurations:

- Delta connection for low voltage
- Star circuit for high voltage

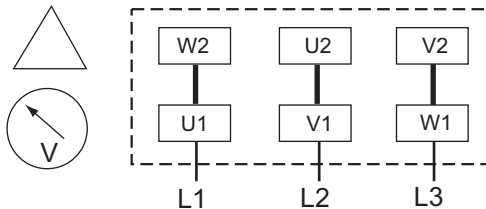

Fig. 10: Delta connection

The 3 wires are connected in series. Their connection points are connected to the mains. The voltage per phase is equal to the mains voltage, while the mains current is $\sqrt{3}$ times the phase current. The delta connection is marked with the Δ symbol. The voltage between the incoming mains supply lines is called mains voltage. The mains current is the current flowing in the incoming supply lines.

Connect the three phase motor with delta connection

- ▶ Connect the three phase motor according to the connection diagram.

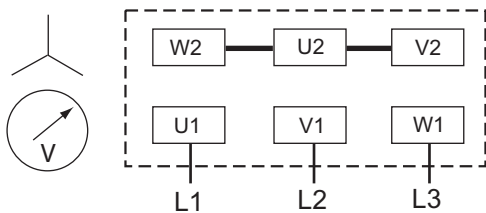

Fig. 11: Star circuit

The ends of the 3 phases are connected in the star point. The terminal voltage is $\sqrt{3}$ times the phase voltage, the mains current is equal to the phase current. The star circuit is marked with the Y symbol.

Connect the three phase motor with star circuit

- ▶ Connect the three phase motor according to the connection diagram.

5.7.2 Connect three phase motor with 12-pin terminal board

There are 3 different circuit configurations:

- Double star circuit for low voltage
- Delta connection for medium voltage
- Star circuit for high voltage



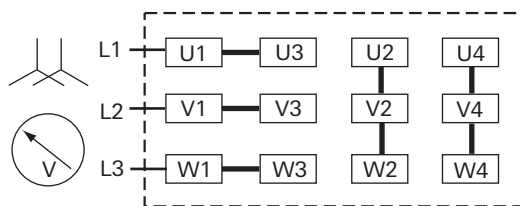

Fig. 12: Double star circuit

Connect the three phase motor with double star circuit

- ▶ Connect the three phase motor according to the connection diagram.

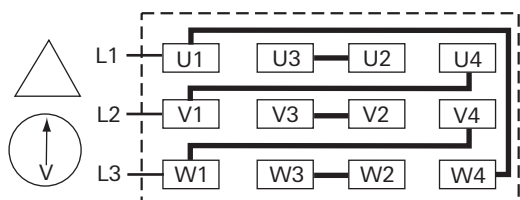

Fig. 13: Delta connection

Connect the three phase motor with delta connection

- ▶ Connect the three phase motor according to the connection diagram.

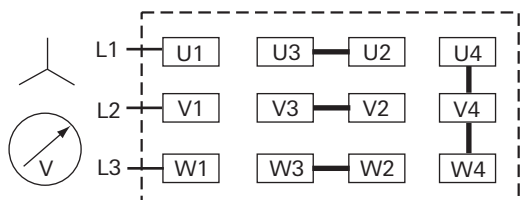

Fig. 14: Star circuit

Connect the three phase motor with star circuit

- ▶ Connect the three phase motor according to the connection diagram.

5.7.3 Checking the direction of rotation

NOTICE

Equipment damage from incorrect direction of rotation

The direction of rotation must be checked on vacuum pumps with three phase motors. If the vacuum pump has an incorrect direction of rotation, damage may be caused to the pumping system after a short time.

- ▶ Determine the intended direction of rotation based on the arrow sticker.
- ▶ Fill in the operating fluid only after that.

Procedure

1. Switch on the vacuum pump briefly (2 to 3 seconds).
 - The motor and motor fan must rotate counter-clockwise (see the arrow on the fan cover).
2. If the direction of rotation is incorrect, exchange the 2 phases on the connection cable.

5.7.4 Setting the motor protection switch

Motor protection switches are current-dependent protective devices for the drive motors. Protection switches with slow tripping characteristics are suitable.

An increase of 1.5 times the rated current over a 2 minute period is permissible for the drive motors (in accordance with EN 60034-1), without tripping the motor protection switch.

Procedure

1. Take the settings for the motor protection switch from the following table.
2. Take into consideration that certain operating conditions (for example, cold vacuum pump start) can cause short-term increases in current consumption.
3. Set the desired value on the motor protection switch.

Voltage [V]	Frequency [Hz]	Motor rating [kW]	I_N [A]	I_{max} [A]
190 – 200	50	13.5	54.2	494
220 – 230	50	13.5	47.1	429
380 – 400	50	13.5	27.1	247
208	60	15.0	54.7	449
220	60	15.0	52.9	482
230	60	15.0	51.9	504
440	60	15.0	26.5	242
460	60	15.0	25.9	252

Tbl. 7: Motor protection switch settings for Hena 401 global motor

Voltage [V]	Frequency [Hz]	Motor rating [kW]	I_N [A]	I_{max} [A]
200	50	13.5	54.2	494
346	50	13.5	31.3	285
220	60	15.5	56.9	467
380	60	15.0	32.9	270

Tbl. 8: Motor protection switch settings for Hena 401 Asian motor

Voltage [V]	Frequency [Hz]	Motor rating [kW]	I_N [A]	I_{max} [A]
190 – 200	50	15.0	62.3	630
220 – 230	50	15.0	54.2	548
380 – 400	50	15.0	31.2	316
208	60	18.5	66.5	579
220	60	18.5	64.4	612
230	60	18.5	64.0	628
440	60	18.5	32.2	306
460	60	18.5	32.0	314

Tbl. 9: Motor protection switch settings for Hena 631 global motor

Voltage [V]	Frequency [Hz]	Motor rating [kW]	I_N [A]	I_{max} [A]
200	50	15.0	64.0	653
346	50	15.0	37.0	378
220	60	18.5	66.1	661
380	60	18.5	38.3	383

Tbl. 10: Motor protection switch settings for Hena 631 Asian motor

5.7.5 Frequency inverter for vacuum pumps with 3-phase motor

Rotary vane pumps with variable rotation speed can be operated within a mains frequency range of 35 to 60 Hz. Start-up is ramped (maximum run-up time: 30 s). Shutdown can take place immediately.



5.7.6 Connecting the PTC thermistor tripping unit



Tripping units store the shut-down

Pfeiffer Vacuum recommends connecting motors with PTC in the stator winding to a PTC resistor tripping device for protection against overload.

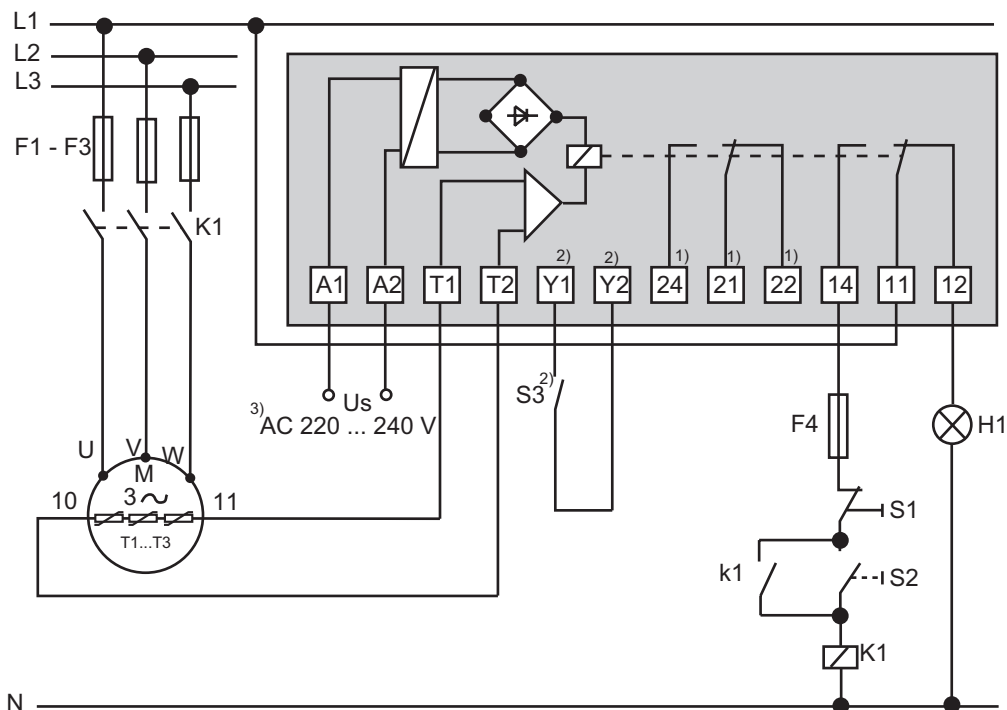

Fig. 15: Connection example with PTC thermistor tripping unit

U _s	Control voltage	T1 – T3	PTC resistor sensor
S ₁	OFF button	H1	Tripping indicator
S ₂	ON button	M	Motor, 3-phase
S ₃	RESET button	1)	For devices with two relay outputs only
K1	Contactor	2)	For MSR type (model) only
F1 – F4	Fuses	3)	Only for order no.: P 4768 052 FQ and P 4768 052 FE

Procedure

- ▶ After shut-down, switch the tripping unit back on manually via the installed RESET button or via the external RESET S3.
 - Switching on mains detected as automatic RESET.

6 Operation

6.1 Putting the vacuum pump into operation

⚠ WARNING

Danger of poisoning due to toxic process media escaping from the exhaust pipe

During operation with no exhaust line, the vacuum pump allows exhaust gases and vapors to escape freely into the air. There is a risk of injury and fatality due to poisoning in processes with toxic process media.

- ▶ Observe the pertinent regulations for handling toxic process media.
- ▶ Safely purge toxic process media via an exhaust line.
- ▶ Use appropriate filter equipment to separate toxic process media.

⚠ WARNING

Tilting danger! Serious injury due to tilting of the product

There is a danger of the vacuum pump not attached tipping over due to changes in the center of gravity or incorrect loading. Serious injuries due to trapping or crushing of limbs, e.g. feet, are the result.

- ▶ Do not use the vacuum pump as a climbing aid.
- ▶ Do not exert any force on the product.
- ▶ Ensure that the product has a safe centre of gravity, when mounting components.
- ▶ Wear protective equipment, e.g. protective shoes

⚠ CAUTION

Danger of injury from bursting as a result of high pressure in the exhaust line

Faulty or inadequate exhaust pipes lead to dangerous situations, e.g. increased exhaust pressure. There is a danger of bursting. Injuries caused by flying fragments, the escaping of high pressure, and damage to the unit cannot be excluded.

- ▶ Route the exhaust line without shut-off units.
- ▶ Observe the permissible pressures and pressure differentials for the product.
- ▶ Check the function of the exhaust line on a regular basis.

Before switching on

1. Check the operating fluid in the sight glass.
2. Compare the voltage and frequency specifications on the motor rating plate with the available mains voltage and frequency.
3. Protect the vacuum pump from sucking in contamination using suitable measures.
4. Check the operating fluid at regular intervals.
5. Check the exhaust connection for free passage (max. permissible pressure: atmospheric pressure).
6. Open the cooling water supply.

6.2 Switching on the vacuum pump

⚠ WARNING

Risk of burns from ejected hot oil mist

During operation, hot pressurized oil mist escapes from the operating fluid separator.

- ▶ Only operate the vacuum pump with the filler screw securely fitted.
- ▶ Open the locking screws on the separator only while the vacuum pump is switched off.



⚠ CAUTION**Risk of injury from entrapment of body parts**

After a power failure or a standstill as a result of overheating, the motor restarts automatically. A risk exists of minor injury to fingers and hands (e.g., hematoma), from direct contact with the vacuum flange.

- ▶ Maintain sufficient distance to the vacuum flange during all work.
- ▶ Safely disconnect motor from the mains.
- ▶ Secure the motor against re-start.

⚠ CAUTION**Danger of burns on hot surfaces**

Depending on the operating and ambient conditions, the surface temperature of the vacuum pump can increase to above 70 °C.

- ▶ Provide suitable touch protection.

NOTICE**Risk of damage to the drive from increased motor current consumption**

At an intake pressure of approximately 300 hPa and under unfavorable operating conditions (such as for example exhaust side counterpressure), the power input exceeds the rated current.

- ▶ Limit the maximum power input of 1.5 times the rated current to max. 2 minutes (in accordance with EN 60034-1).

**Cycle operation**

Cycle operation with maximum 10 cycles per hour is possible.

Longer operating phases and short downtimes permit a functionally safe operating condition of the vacuum pump.

Operating Conditions

- You can switch on the vacuum pump in every pressure range, between atmospheric pressure and final pressure.
- The optimal operating condition of the vacuum pump is continuous operation.
- When pumping down dry gases, no special precautions are required.
- Low final pressures are possible with the gas ballast valve closed.

Switching on the vacuum pump

1. If required, switch the vacuum pump on in each pressure range.
2. Close the vacuum connection and gas ballast valve.
3. Allow the vacuum pump to warm up prior to process start, with the vacuum connection closed, for approx. 30 minutes.

Inspect operating fluid level

1. Regularly check the operating fluid level while the vacuum pump is running and at operating temperature.
2. Make sure that the fill level is within the markings of the sight glass.
3. Check the operating fluid fill level daily during continuous operation, and every time the vacuum pump is switched on.

6.3 Operating the rotary vane pump with gas ballast

NOTICE

Risk of damage from condensation in vacuum pump
 During operation without gas ballast, condensation may form as a result of the vapor compatibility of the vacuum pump being exceeded.

- ▶ Pump condensable vapors only when the vacuum pump is warm and the gas ballast valve open.
- ▶ Allow the vacuum pump to run on after process end for another 30 minutes with the gas ballast valve open.
 - This cleans the operating fluid and protects the vacuum pump against corrosion.

i **No intermediate settings possible**
 An intermediate setting between open and closed is not possible.

The gas ballast valve supplies air to the working chamber of the vacuum pump periodically at the beginning of the compression phase. When pumping down vapors, this air prevents condensation within certain limits in the vacuum pump.

Required tool

- Flat-tip screwdriver

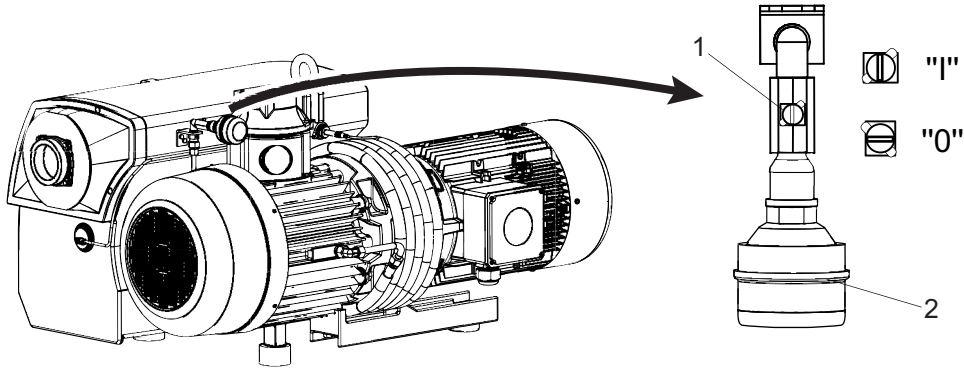

Fig. 16: Gas ballast valve

- 1 Gas ballast valve
- 2 Gas ballast filter

Behavior with process gases with condensable vapors

- ▶ Operate the vacuum pump with gas ballast, i.e. with the gas ballast valve open.

Open gas ballast valve

- ▶ To open, turn the screw on the gas ballast valve to the "1" position.

Close gas ballast valve

- ▶ To close, turn the screw on the gas ballast valve to the position "0".

6.4 Refilling operating fluid

Prerequisite

- Vacuum pump switched off

Required consumables

- Operating fluid

Required tool

- Open-end wrench, **WAF 27**

Required aids

- Funnel (optional)



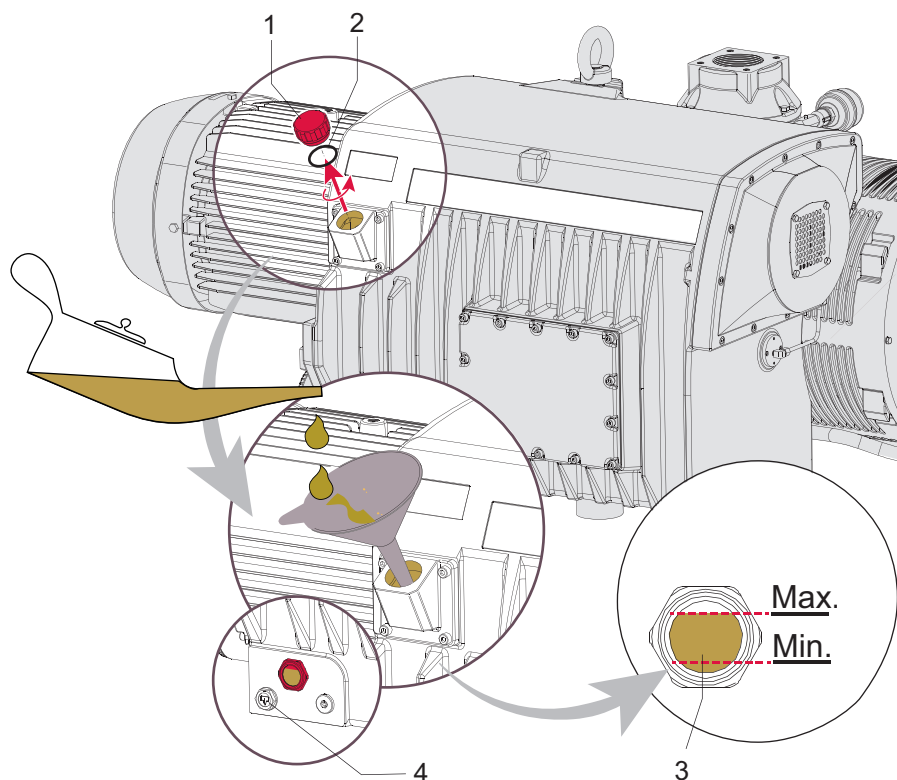

Fig. 17: Refilling operating fluid

- | | |
|-------------------------------|---------------|
| 1 Filler screw with manometer | 3 Sight glass |
| 2 O-ring | 4 Drain screw |

Procedure

1. Unscrew the filler screw.
2. With the vacuum pump at operating temperature, refill with operating fluid up to the top marking before the minimum fill level is reached.
3. Screw in the filler screw again.
 - Be careful with the O-ring.

6.5 Switching off the vacuum pump

NOTICE

Contamination from operating fluid backflow

After the vacuum pump is switched off, there is a risk that the connected vacuum system can become contaminated by backflow. The safety valve on the vacuum pump is not suitable for longer-term sealing.

- ▶ Install an additional shut-off valve in the intake line.
- ▶ Shut off the intake line immediately after switching off the vacuum pump.

NOTICE

Contamination of the vacuum chamber from operating fluid backflow

After the vacuum pump is switched off, there is a risk that the connected vacuum system can become contaminated by backflow.

- ▶ Vent the vacuum chamber, regardless of its size, within 30 seconds.
- ▶ Shut off the intake line with an additional shut-off valve, after the vacuum pump is switched off during longer venting operations.



Rotary vane vacuum pumps of the HenaLine have an integrated non-return valve on the suction side. The non-return valve closes automatically when the vacuum pump is switched off, preventing the return flow of gas and processing materials into the intake line.

Procedure

1. If required, switch the vacuum pump off in each pressure range.
2. Switch the mains switch off or securely disconnect the drive motor from the mains.
3. Shut off the cooling water flow.
4. Install an additional shut-off valve in the intake line to ensure that the vacuum is maintained in the vacuum chamber.



7 Maintenance

7.1 Maintenance instructions

⚠ WARNING

Health hazard through poisoning from toxic contaminated components or devices

Toxic process media result in contamination of devices or parts of them. During maintenance work, there is a risk to health from contact with these poisonous substances. Illegal disposal of toxic substances causes environmental damage.

- ▶ Take suitable safety precautions and prevent health hazards or environmental pollution by toxic process media.
- ▶ Decontaminate affected parts before carrying out maintenance work.
- ▶ Wear protective equipment.

⚠ WARNING

Tilting danger! Serious injury due to tilting of the product

There is a danger of the vacuum pump not attached tipping over due to changes in the center of gravity or incorrect loading. Serious injuries due to trapping or crushing of limbs, e.g. feet, are the result.

- ▶ Do not use the vacuum pump as a climbing aid.
- ▶ Do not exert any force on the product.
- ▶ Ensure that the product has a safe centre of gravity, when mounting components.
- ▶ Wear protective equipment, e.g. protective shoes

⚠ CAUTION

Danger of injury from moving parts

After a power failure or a standstill as a result of overheating, the motor restarts automatically. There is a risk of injury to fingers and hands if they enter the operating range of rotating parts.

- ▶ Safely disconnect motor from the mains.
- ▶ Secure the motor against reactivation.
- ▶ Dismantle the vacuum pump for inspection, away from the system if necessary.

⚠ CAUTION

Danger of burns on hot surfaces

Depending on the operating and ambient conditions, the surface temperature of the vacuum pump can increase to above 70 °C.

- ▶ Provide suitable touch protection.

NOTICE

Danger of property damage from improper maintenance

Unprofessional work on the vacuum pump will lead to damage for which Pfeiffer Vacuum accepts no liability.

- ▶ We recommend taking advantage of our service training offering.
- ▶ When ordering spare parts, specify the information on the nameplate.

The following section describes the tasks for cleaning and maintaining the vacuum pump. More advanced works are described in the service instructions.

Prerequisites

- Vacuum pump switched off
- Vacuum pump vented to atmospheric pressure
- Vacuum pump cooled



Preparing maintenance

- ▶ Safely disconnect the drive motor from the mains.
- ▶ Secure the motor against switching back on.
- ▶ For maintenance work, only dismantle the vacuum pump to the extend needed.
- ▶ Dispose of used operating fluid according to applicable regulations in each case.
- ▶ When using synthetic operating fluid, please observe the associated application instructions.
- ▶ Only clean the pump parts using industrial alcohol, isopropanol or similar media.

7.2 Checklist for inspection and maintenance



Notes on maintenance intervals

Depending on the process, the required maintenance intervals may be shorter than the reference values specified in the table.

- Consult with Pfeiffer Vacuum Service about shorter maintenance intervals for extreme loads or for specific processes.



Maintenance intervals

You can carry out the **inspection** yourself.

We recommend Pfeiffer Vacuum Service for carrying out maintenance work of **Maintenance Level 1** and **Maintenance Level 3** (revision). If the required intervals listed below are exceeded, or if maintenance work is carried out improperly, no warranty or liability claims are accepted on the part of Pfeiffer Vacuum. This also applies wherever parts other than original spare parts are used.

Action described in document	Inspection		Maintenance level 1 OI	Maintenance level 3	Required material
	daily	every 6 months	yearly	every 5 years	
Inspection					
<ul style="list-style-type: none"> • Check the operating fluid filling level • Check the vacuum pump for operating fluid leaks 	■				
<ul style="list-style-type: none"> • Clean the outside of the pump housing • If fitted, clean the gas ballast valve filter • If fitted, check and clean the air/oil heat exchanger 		■			
Maintenance Level 1 – operating fluid and filter change					
<ul style="list-style-type: none"> • Changing the operating fluid • Changing the operating fluid filter • Changing the exhaust filter 			■		<ul style="list-style-type: none"> • Operating fluid • Maintenance set level 1
Maintenance Level 3 – overhaul including changing all wear parts					
<ul style="list-style-type: none"> • Change the bearings, seals and valves • Vane change, optional 				■	Contact Pfeiffer Vacuum Service. <ul style="list-style-type: none"> • Set of vanes, optional • Overhaul kit

Tbl. 11: Maintenance intervals



7.3 Changing the operating fluid

WARNING

Health hazard and risk of environmental damage from toxic contaminated operating fluid

Toxic process media can cause operating fluid contamination. When changing the operating fluid, there is a health hazard due to contact with poisonous substances. Illegal disposal of toxic substances causes environmental damage.

- ▶ Wear suitable personal protective equipment when handling these media.
- ▶ Dispose of the operating fluid according to locally applicable regulations.

CAUTION

Scalding from hot operating fluid

Danger of burns when draining operating fluid if it comes into contact with the skin.

- ▶ Wear protective equipment.
- ▶ Use a suitable collection receptacle.



Pfeiffer Vacuum recommends determining the precise service life of the operating fluid in the first operating year.

The service life may deviate from the reference value specified depending on thermic and chemical loads, and the accumulation of suspended particles and condensate in the operating fluid.



Operating fluid type

Fundamentally, when filling, refilling, or changing operating fluid, you must always use the operating fluid type specified on the rating plate. Should process conditions change, you can convert to a different operating fluid type.



Safety data sheets

You can obtain the safety data sheets for operating fluids from Pfeiffer Vacuum on request, or from the [Pfeiffer Vacuum Download Center](#).

The usable life of operating fluid is dependent on the area of application of the rotary vane vacuum pumps.

Instructions for when operating fluid should be changed

- The vacuum pump does not reach the specified ultimate pressure.
- Operating fluid is perceptibly polluted, milky, or cloudy when viewed through the sight glass.
- It is possible to detect thermal aging of the operating fluid from its color identification number (applies to mineral oils only).

7.3.1 Determine degree of aging of P3 operating fluid

WARNING

Health hazard and risk of environmental damage from toxic contaminated operating fluid

Toxic process media can cause operating fluid contamination. When changing the operating fluid, there is a health hazard due to contact with poisonous substances. Illegal disposal of toxic substances causes environmental damage.

- ▶ Wear suitable personal protective equipment when handling these media.
- ▶ Dispose of the operating fluid according to locally applicable regulations.

You can determine the degree of aging of P3 operating fluid in clean processes using the color chart (in accordance with DIN 51578). The supplementary sheet with the document number PK0219 can be obtained from the [Pfeiffer Vacuum Download Center](#).



Prerequisites

- Vacuum pump switched off
- Vacuum pump is vented to atmospheric pressure on the suction side
- Vacuum pump cooled

Required aids

- Test tube
- Pipette with flexible hose

Determine degree of aging of P3 operating fluid

1. Unscrew the filler screw.
2. Use the pipette to extract a sample of the operating fluid from the filling port.
3. Pour the sample into a test tube.
4. Check the sample in bright light.
5. If it is a reddish-brown color at the latest (corresponding with color identification number 5), change the operating fluid.
6. Screw in the filler screw.

7.3.2 Change the operating fluid

⚠ WARNING

Health hazard and risk of environmental damage from toxic contaminated operating fluid

Toxic process media can cause operating fluid contamination. When changing the operating fluid, there is a health hazard due to contact with poisonous substances. Illegal disposal of toxic substances causes environmental damage.

- ▶ Wear suitable personal protective equipment when handling these media.
- ▶ Dispose of the operating fluid according to locally applicable regulations.

⚠ CAUTION

Scalding from hot operating fluid

Danger of burns when draining operating fluid if it comes into contact with the skin.

- ▶ Wear protective equipment.
- ▶ Use a suitable collection receptacle.

i

Cleaning by changing the operating fluid

Pfeiffer Vacuum recommends, in cases of heavy contamination with process residues, cleaning the inside of the vacuum pump with several operating fluid changes.

i

Checking the fill level

The correct fill level is between the MIN/MAX markings or within the ring mark on the sight glass.

Prerequisites

- Vacuum pump switched off
- Vacuum pump vented to atmospheric pressure
- Vacuum pump has cooled so that it can be touched
- Operating fluid still warm

Required consumables

- Operating fluid

Required tools

- Open-end wrench, **WAF 27**
- Open-end wrench, **WAF 30**

Required aids

- Collection receptacle (> 16 l)



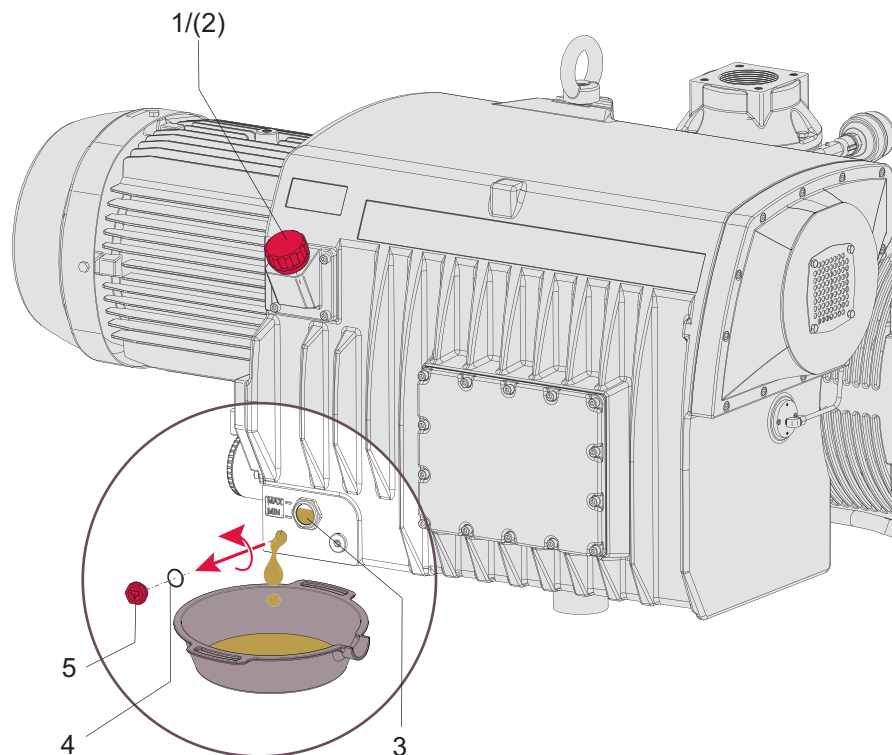

Fig. 18: Draining the operating fluid

- | | |
|-------------------------------|---------------|
| 1 Filler screw with manometer | 4 O-ring |
| 2 O-ring | 5 Drain screw |
| 3 Sight glass | |

Draining the operating fluid

1. Unscrew the filler screw.
 - Be careful with the O-ring.
2. Place a collection receptacle below the drain hole.
3. Unscrew the drain screw.
 - Be careful with the O-ring.
4. Allow operating fluid to drain into collection receptacle.

Filling fresh operating fluid

1. Screw in the drain screw.
 - Be careful with the O-ring.
2. Fill new operating fluid.
3. Check level.
4. Screw in the filler screw.
 - Be careful with the O-ring.

7.3.3 Rinsing and cleaning the rotary vane vacuum pump



Cleaning by changing the operating fluid

Pfeiffer Vacuum recommends, in cases of heavy contamination with process residues, cleaning the inside of the vacuum pump with several operating fluid changes.

Required consumable materials

- Operating fluid
- Maintenance set level 1

Required aids

- Collection receptacle (> 16 l)



Change operating fluid for cleaning

1. Operate the vacuum pump with the gas ballast open, until it is warm.
2. Perform an operating fluid change.
3. Check the pollution level and repeat the changing of the operating fluid if necessary.
4. In case of highly contaminated operating fluid, replace the operating fluid filter and the exhaust filter.

7.3.4 Changing the operating fluid filter

The operating fluid filter must be changed:

- in event of saturation
 - You can recognize a saturated operating fluid filter by the fact that the filter housing is cool on the outside while the rotary vane pump is running at operating temperature.
- with each operating fluid change
- according to maintenance level

Prerequisites

- Vacuum pump switched off
- Vacuum pump vented to atmospheric pressure
- Operating fluid drained

Required tool

- Strap wrench

Required aids

- Collection receptacle (> 1 l)

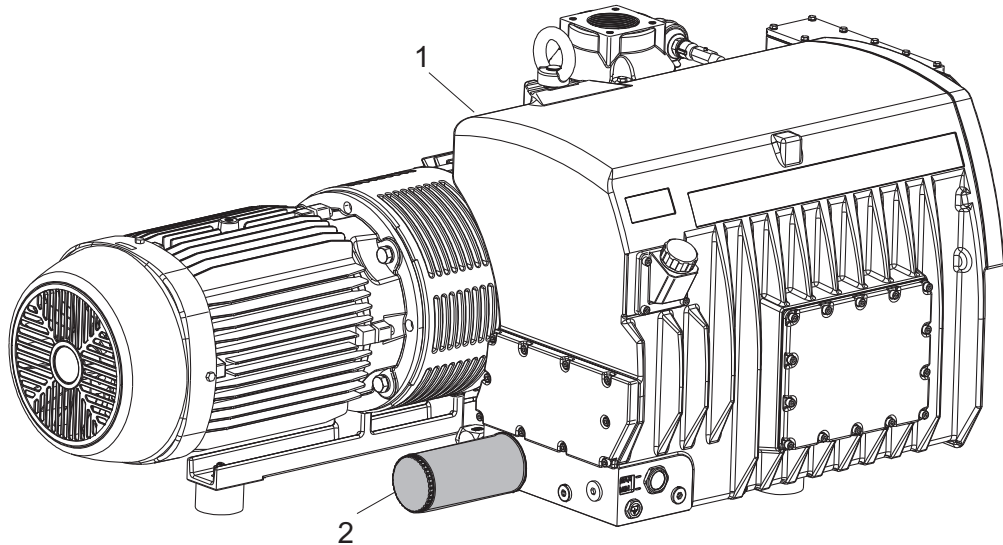

Fig. 19: Changing the operating fluid filter

- | | |
|-----------------------------|--------------------------|
| 1 Operating fluid separator | 2 Operating fluid filter |
|-----------------------------|--------------------------|

Procedure

1. Place a collection receptacle below the operating fluid filter.
2. Unscrew the operating fluid filter using a strap wrench.
 - Pay attention to escaping operating fluid.
3. Apply oil to the sealing surface of the operating fluid filter.
4. Screw the operating fluid filter on finger-tight.



7.4 Change the exhaust filter in the operating fluid separator

⚠ WARNING

Health hazard through poisoning from toxic contaminated components or devices

Toxic process media result in contamination of devices or parts of them. During maintenance work, there is a risk to health from contact with these poisonous substances. Illegal disposal of toxic substances causes environmental damage.

- ▶ Take suitable safety precautions and prevent health hazards or environmental pollution by toxic process media.
- ▶ Decontaminate affected parts before carrying out maintenance work.
- ▶ Wear protective equipment.



Change the exhaust filter annually

Pfeiffer Vacuum recommends replacing the exhaust filter in the operating fluid separator annually, depending on the work process and the contamination incurred during the process.

Signs for saturation of the exhaust filter:

- higher current consumption of the motor
- increased emission of operating fluid mist at the gas outlet
- increased pressure in the operating fluid separator (pressure gage display in the red area).

7.4.1 Dismantling the exhaust filters

Prerequisites

- Vacuum pump switched off
- Vacuum pump vented to atmospheric pressure
- Vacuum pump cooled

Required tools

- Allen key, **WAF 6**
- Socket key, **WAF 10**
- Slot screwdriver

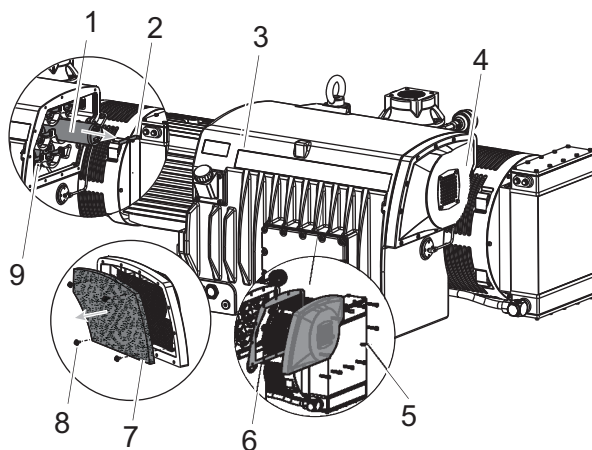

Fig. 20: Dismantling the exhaust filters

- | | |
|-----------------------------|-------------------|
| 1 Exhaust filter | 6 Flat seal |
| 2 Filter spring | 7 Filter material |
| 3 Operating fluid separator | 8 Screw (4x) |
| 4 Separator cover plate | 9 Filter support |
| 5 Screw (12x) | |

Procedure

1. Remove the separator cover plate.
 - Pay attention to the flat seal
2. Remove the filter material.



3. Loosen the screw of the filter springs to relieve tension in the springs.
4. Remove the filter springs.
5. Pull the exhaust filter out of the operating fluid separator.
 - If necessary, remove the filter supports.

7.4.2 Mounting the exhaust filters

Prerequisites

- Vacuum pump switched off
- Vacuum pump vented to atmospheric pressure
- Vacuum pump cooled

Required consumables

- Maintenance kit – Maintenance level 1

Required tools

- Allen key, **WAF 6**
- Socket key, **WAF 10**
- Flat-head screwdriver
- Calibrated torque wrench (tightening factor ≤ 2.5)

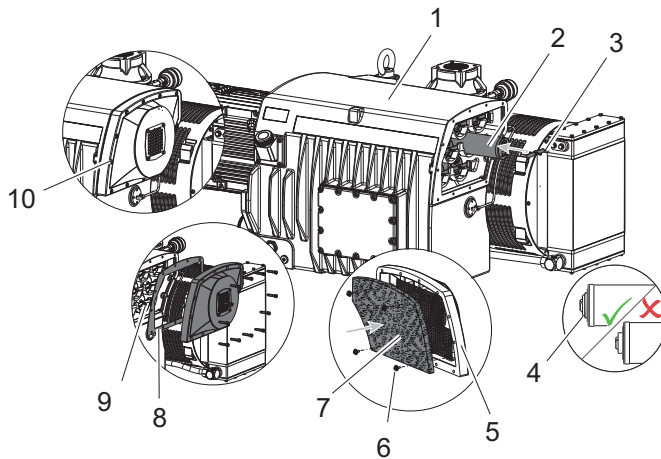

Fig. 21: Mounting the exhaust filters

1	Operating fluid separator	6	Screw (4x)
2	Exhaust filter	7	Filter material
3	Filter springs	8	Flat seal
4	O-ring	9	Filter support
5	Separator cover plate	10	Screw (12x)

Procedure

1. Check whether the o-rings are seated on the face side of the exhaust air filters.
2. Mount the exhaust filters using the filter springs.
 - The arrow on the filter indicates the installation orientation. The arrow must point upwards (↑).
3. Ensure correct seating of the filter springs.
4. Tighten the screws of the filter springs.
5. Insert the new filter material into the separator cover plate.
6. Fit the separator cover plate with new flat seal.
7. Tighten the screws on the separator cover plate evenly.
 - Tightening torque: **21 Nm**.

During operation, the new exhaust filter becomes saturated with oil. It is therefore normal for the operating fluid fill level to drop slightly after the filters were changed.

7.5 Cleaning the intake strainer

The intake strainer in the vacuum connection upper section must be cleaned:

- when the throughput decreases
- if there is visible contamination



Prerequisites

- Vacuum pump switched off
- Vacuum pump is vented to atmospheric pressure on the suction side
- Vacuum pump cooled

Required tool

- Hexagonal wrench, **WAF 13**

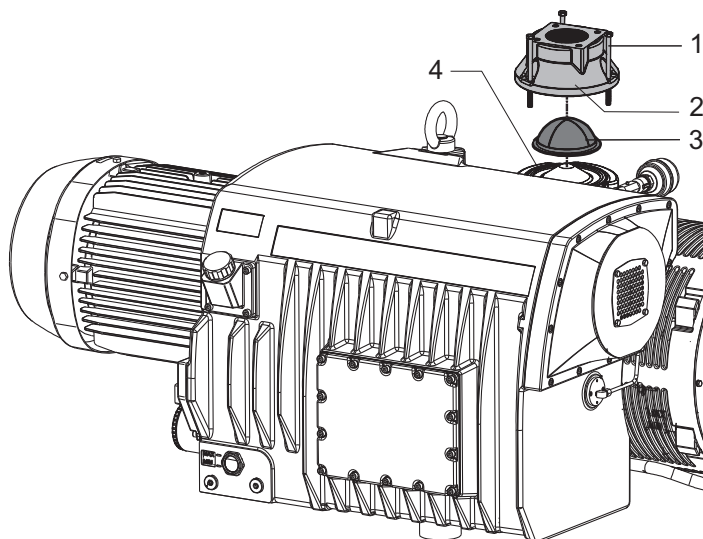

Fig. 22: Dismantling / assembling the intake strainer

- | | |
|---------------------|-------------------|
| 1 Cylinder screw | 3 Intake strainer |
| 2 Vacuum connection | 4 O-ring |

Dismantling the intake strainer

1. Unscrew the cheesehead screws.
2. Remove the vacuum connection.
 - Be careful with the O-ring.
3. Remove the intake strainer from the intake duct.

Clean all parts and examine for wear

1. Clean all parts.
2. Examine all parts for wear.

Mounting the intake strainer

1. Insert the intake strainer into the intake duct.
2. Fit the vacuum connection.
 - Be careful with the O-ring.
3. Screw on the cylinder screws.

7.6 Cleaning the gas ballast filter

The gas ballast filter is soiled if the vacuum pump takes in ambient air containing dust during gas ballast operation. As the soiling increases, the throughput of the gas ballast filter decreases. The risk of condensation and corrosion in the vacuum pump increases.

Required consumables

- Compressed air



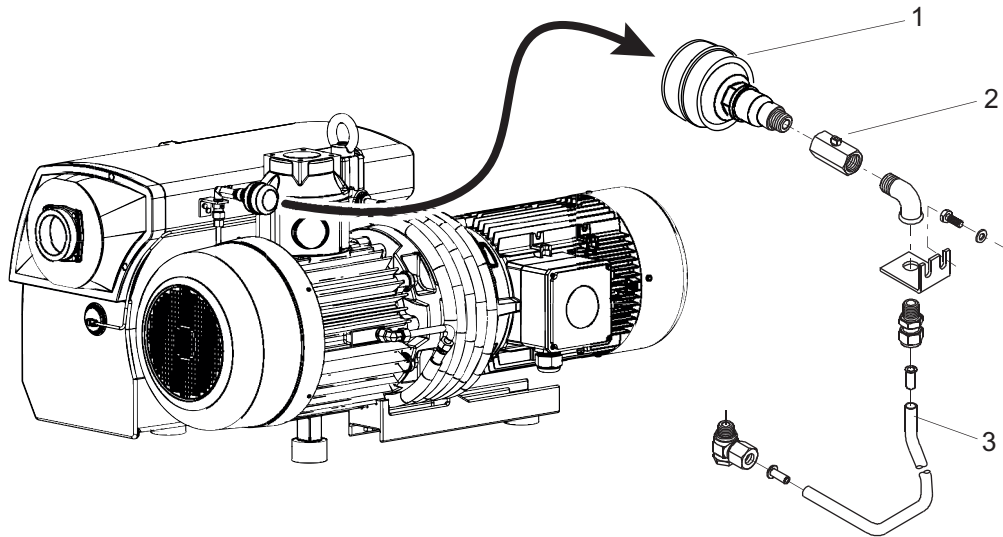

Fig. 23: Cleaning the gas ballast filter

- | | |
|----------------------|--------------------|
| 1 Gas ballast filter | 3 Gas ballast line |
| 2 Gas ballast valve | |

Removing and cleaning the gas ballast filter

1. Dismantle the gas ballast filter.
2. Clean the gas ballast filter using compressed air.
3. Replace the gas ballast filter in the event of major contamination or damage.
4. Check and clean the gas ballast line using compressed air if the gas ballast line is clogged.

7.7 Cleaning the operating fluid return line

In order to guarantee correct functioning of the operating fluid return, Pfeiffer Vacuum recommends cleaning the operating fluid return line and the float valve:

- with each operating fluid change
- with each exhaust filter change

This allows the vacuum pump to reach the final pressure and no operating fluid escapes at the exhaust flange.

Prerequisites

- Vacuum pump switched off
- Vacuum pump vented to atmospheric pressure
- Vacuum pump cooled
- Operating fluid drained
- Exhaust filter changed in the operating fluid separator

Required consumable material

- Operating fluid of the vacuum pump
- Parts according to the maintenance kit
- Compressed air

Required tool

- Hexagonal wrench, **WAF 4**



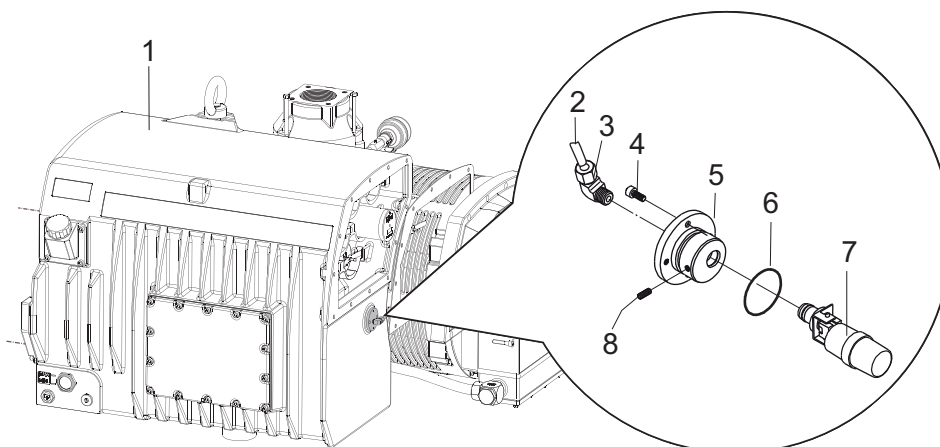

Fig. 24: Operating fluid return with float valve

1	Operating fluid separator	5	Valve holder
2	Operating fluid return line	6	O-ring
3	Elbow union	7	Float valve
4	Screws	8	Grub screw, set screw

Dismantle the float valve



Operating fluid leaks out

Small amounts of operating fluid may leak out when carrying out the work described below.

1. Where necessary, extract the remaining operating fluid from the float chamber inside the operating fluid separator.
2. Disconnect the operating fluid return line at the elbow union.
3. Remove the screws on the valve holder.
4. If necessary, the screws can be used to press down the valve holder.
5. Remove the valve holder with float valve whilst paying particular attention to the O-ring.
6. Loosen the grub screw in the valve holder.
7. Remove the float valve from the valve holder.

Clean the float valve and operating fluid return line

1. Clean the float valve.
2. Clean operating fluid return line with compressed air.

Mounting the float valve

1. Check the function of the float valve.
 - Make sure that the float moves easily by its own weight.
 - Make sure that the axial sealing surface on the floater is clean.
2. Mount the float valve in the correct installation position in the valve holder.
3. Mount the valve holder with a new o-ring onto the operating fluid separator.
4. Mount the elbow union and the operating fluid return line.
5. Refill the operating fluid.
6. Start up the vacuum pump.
7. Perform a final pressure test on the operating fluid return line to check for leaks.



7.8 Changing the operating fluid type



Possibilities for changing the operating fluid type

The operating fluid type can be changed between mineral operating fluid – **P3** – and synthetic operating fluid – **D1** – only.

It is not possible to change from **P3/D1** to **F4/F5** or vice versa.

Required consumables

- 3 times the filling quantity of the new operating fluid

Changing the operating fluid type

1. Change the operating fluid with the new operating fluid **twice** in order to rinse the vacuum pump.
2. Change the exhaust filters in the operating fluid separator.
3. Change the operating fluid filter.
4. Fill the vacuum pump with operating fluid to one third full.
5. Note the currently used operating fluid type at a suitable location on the vacuum pump, e.g. on the rating plate.



8 Decommissioning

8.1 Shutting down for longer periods

Before shutting down the vacuum pump, observe the following instructions to adequately protect the interior of the vacuum pump (pumping system) against corrosion:

1. Switch off the vacuum pump.
2. Vent the vacuum pump.
3. Allow the vacuum pump to cool down.
4. Remove the vacuum pump from the vacuum system if necessary.
5. Change the operating fluid.
6. Start the vacuum pump and bring it to operating temperature in order to wet the inside of the vacuum pump with fresh operating fluid.
7. Seal the connections with the original protective covers.
8. Store the vacuum pump in dry, dust-free rooms, within the specified ambient conditions.
9. Pack the vacuum pump together with a drying agent in a plastic bag, and seal the vacuum pump airtight if it is to be stored in rooms with damp or aggressive atmospheres.
10. For longer storage periods (> 2 years), Pfeiffer Vacuum recommends changing the operating fluid again prior to recommissioning.

8.2 Recommissioning

NOTICE

Risk of damage to vacuum pump as a result of operating fluid aging

The operating fluid usability is limited (max. 2 years). Prior to recommissioning, following a shutdown of **2 years or more**, carry out the following work.

- ▶ Change the operating fluid.
- ▶ Change the radial shaft seal rings and other elastomer parts if required.
- ▶ Observe the maintenance instructions – consult Pfeiffer Vacuum if necessary.

9 Recycling and disposal

WARNING

Health hazard through poisoning from toxic contaminated components or devices

Toxic process media result in contamination of devices or parts of them. During maintenance work, there is a risk to health from contact with these poisonous substances. Illegal disposal of toxic substances causes environmental damage.

- ▶ Take suitable safety precautions and prevent health hazards or environmental pollution by toxic process media.
- ▶ Decontaminate affected parts before carrying out maintenance work.
- ▶ Wear protective equipment.



Environmental protection

You **must** dispose of the product and its components in accordance with all applicable regulations for protecting people, the environment and nature.

- Help to reduce the wastage of natural resources.
- Prevent contamination.



Environmental protection

The product and its components **must be disposed of in accordance with the applicable regulations relating to environmental protection and human health**, with a view to reducing natural resource wastage and preventing pollution.

9.1 General disposal information

Pfeiffer Vacuum products contain materials that you must recycle.

- ▶ Dispose of our products according to the following:
 - Iron
 - Aluminium
 - Copper
 - Synthetic
 - Electronic components
 - Oil and fat, solvent-free
- ▶ Observe the special precautionary measures when disposing of:
 - Fluoroelastomers (FKM)
 - Potentially contaminated components that come into contact with media

9.2 Dispose of rotary vane pump

Pfeiffer Vacuum rotary vane pumps contain materials that you must recycle.

1. Fully drain the lubricant.
2. Dismantle the motor.
3. Decontaminate the components that come into contact with process gases.
4. Separate the components into recyclable materials.
5. Recycle the non-contaminated components.
6. Dispose of the product or components in a safe manner according to locally applicable regulations.



10 Malfunctions

⚠ CAUTION

Danger of injury from moving parts

After a power failure or a standstill as a result of overheating, the motor restarts automatically. There is a risk of injury to fingers and hands if they enter the operating range of rotating parts.

- ▶ Safely disconnect motor from the mains.
- ▶ Secure the motor against reactivation.
- ▶ Dismantle the vacuum pump for inspection, away from the system if necessary.

⚠ CAUTION

Danger of burns on hot surfaces

In the event of a fault, the surface temperature of the vacuum pump can increase to above 105 °C.

- ▶ Allow the vacuum pump to cool down before carrying out any work.
- ▶ Wear personal protective equipment if necessary.

NOTICE

Danger of property damage from improper maintenance

Unprofessional work on the vacuum pump will lead to damage for which Pfeiffer Vacuum accepts no liability.

- ▶ We recommend taking advantage of our service training offering.
- ▶ When ordering spare parts, specify the information on the nameplate.

Should malfunctions occur, you can find information about potential causes and how to fix them here:

Problem	Possible causes	Remedy
Vacuum pump will not start	<ul style="list-style-type: none"> • No mains voltage or voltage does not correspond to the motor data 	<ul style="list-style-type: none"> • Check the mains voltage and mains fuse • Check the motor switch.
	<ul style="list-style-type: none"> • Pump temperature too low 	<ul style="list-style-type: none"> • Heat the vacuum pump to > 5 °C.
	<ul style="list-style-type: none"> • Thermal protection switch has triggered 	<ul style="list-style-type: none"> • Determine and eliminate the cause. • Allow the vacuum pump to cool down as required.
	<ul style="list-style-type: none"> • Pumping system contaminated 	<ul style="list-style-type: none"> • Contact Pfeiffer Vacuum Service.
	<ul style="list-style-type: none"> • Pumping system damaged 	<ul style="list-style-type: none"> • Contact Pfeiffer Vacuum Service.
	<ul style="list-style-type: none"> • Motor faulty 	<ul style="list-style-type: none"> • Replace the motor. • Contact Pfeiffer Vacuum Service.
	<ul style="list-style-type: none"> • Coupling defective 	<ul style="list-style-type: none"> • Contact Pfeiffer Vacuum Service.
Vacuum pump switches off after a while after being started	<ul style="list-style-type: none"> • Thermal protection switch of the motor has triggered 	<ul style="list-style-type: none"> • Determine and eliminate the cause of overheating. • Allow the motor to cool down as required.
	<ul style="list-style-type: none"> • Mains fuse triggered due to overload (e.g. cold start) 	<ul style="list-style-type: none"> • Bring vacuum pump to permissible ambient temperature range.
	<ul style="list-style-type: none"> • Exhaust pressure too high 	<ul style="list-style-type: none"> • Check exhaust line outlet openings and exhaust side accessories.

Problem	Possible causes	Remedy
Vacuum pump does not reach the specified final pressure	<ul style="list-style-type: none"> • Measurement result distorted 	<ul style="list-style-type: none"> • Check the measurement instrument. • Check the final pressure without system connected.
	<ul style="list-style-type: none"> • Vacuum pump or connected accessory contaminated 	<ul style="list-style-type: none"> • Clean the vacuum pump. • Check the components for contamination.
	<ul style="list-style-type: none"> • Operating fluid contaminated 	<ul style="list-style-type: none"> • Operate the vacuum pump with the gas ballast valve open over a longer period. • Change the operating fluid.
	<ul style="list-style-type: none"> • Operating fluid level too low 	<ul style="list-style-type: none"> • Top up the operating fluid.
	<ul style="list-style-type: none"> • Leak in system 	<ul style="list-style-type: none"> • Locate and eliminate the leak.
	<ul style="list-style-type: none"> • Vacuum pump is damaged 	<ul style="list-style-type: none"> • Contact Pfeiffer Vacuum Service.
Pumping speed of vacuum pump too low	<ul style="list-style-type: none"> • The intake line is not suitably dimensioned 	<ul style="list-style-type: none"> • Make sure that connections are short and cross sections adequately dimensioned.
	<ul style="list-style-type: none"> • Exhaust pressure too high 	<ul style="list-style-type: none"> • Check exhaust line outlet openings and exhaust side accessories.
Loss of operating fluid	<ul style="list-style-type: none"> • Operating fluid separator leaking 	<ul style="list-style-type: none"> • Check for leaks. • Replace the seal as required.
	<ul style="list-style-type: none"> • Radial shaft seal rings (RSSR) leaking 	<ul style="list-style-type: none"> • Contact Pfeiffer Vacuum Service.
	<ul style="list-style-type: none"> • Exhaust filter saturated or contaminated 	<ul style="list-style-type: none"> • Change the exhaust filter.
	<ul style="list-style-type: none"> • Exhaust filter and seals incorrectly assembled 	<ul style="list-style-type: none"> • Check that the exhaust filter and seals are fitted correctly.
	<ul style="list-style-type: none"> • Operational loss of operating fluid 	<ul style="list-style-type: none"> • Check the oil return in the operating fluid separator.
Unusual noises during operation	<ul style="list-style-type: none"> • Pumping system is contaminated or damaged 	<ul style="list-style-type: none"> • Contact Pfeiffer Vacuum Service.
	<ul style="list-style-type: none"> • Coupling worn 	<ul style="list-style-type: none"> • Contact Pfeiffer Vacuum Service.
	<ul style="list-style-type: none"> • Motor bearing faulty 	<ul style="list-style-type: none"> • Change the motor. • Contact Pfeiffer Vacuum Service.

Tbl. 12: Troubleshooting for rotary vane pumps



11 Service solutions by Pfeiffer Vacuum

We offer first-class service

High vacuum component service life, in combination with low downtime, are clear expectations that you place on us. We meet your needs with efficient products and outstanding service.

We are always focused on perfecting our core competence – servicing of vacuum components. Once you have purchased a product from Pfeiffer Vacuum, our service is far from over. This is often exactly where service begins. Obviously, in proven Pfeiffer Vacuum quality.

Our professional sales and service employees are available to provide you with reliable assistance, worldwide. Pfeiffer Vacuum offers an entire range of services, from [original replacement parts](#) to [service contracts](#).

Make use of Pfeiffer Vacuum service

Whether preventive, on-site service carried out by our field service, fast replacement with mint condition replacement products, or repair carried out in a [Service Center](#) near you – you have various options for maintaining your equipment availability. You can find more detailed information and addresses on our homepage, in the [Pfeiffer Vacuum Service](#) section.

You can obtain advice on the optimal solution for you, from your [Pfeiffer Vacuum representative](#).

For fast and smooth service process handling, we recommend the following:

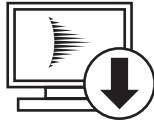

1. Download the up-to-date form templates.
 - [Explanations of service requests](#)
 - [Service requests](#)
 - [Contamination declaration](#)



- a) Remove and store all accessories (all external parts, such as valves, protective screens, etc.).
 - b) If necessary, drain operating fluid/lubricant.
 - c) If necessary, drain coolant.
2. Complete the service request and contamination declaration.



3. Send the forms by email, fax, or post to your local [Service Center](#).

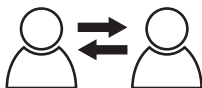

4. You will receive an acknowledgment from Pfeiffer Vacuum.

PFEIFFER VACUUM

Submission of contaminated products

No microbiological, explosive, or radiologically contaminated products will be accepted. Where products are contaminated, or the contamination declaration is missing, Pfeiffer Vacuum will contact you before starting service work. Depending on the product and degree of pollution, **additional decontamination costs** may be incurred.



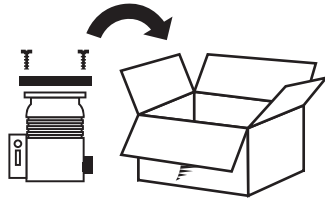

5. Prepare the product for transport in accordance with the provisions in the contamination declaration.
 - a) Neutralize the product with nitrogen or dry air.
 - b) Seal all openings with blind flanges, so that they are airtight.
 - c) Shrink-wrap the product in suitable protective foil.
 - d) Package the product in suitable, stable transport containers only.
 - e) Maintain applicable transport conditions.

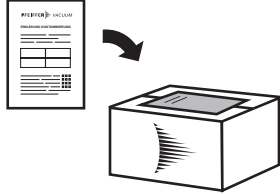

6. Attach the contamination declaration to the **outside** of the packaging.

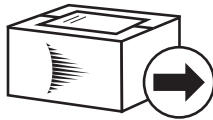

7. Now send your product to your local Service Center.

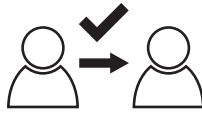

8. You will receive an acknowledgment/quotation, from Pfeiffer Vacuum.

PFEIFFER VACUUM

Our sales and delivery conditions and repair and maintenance conditions for vacuum devices and components apply to all service orders.



12 Spare parts

12.1 Ordering spare part packages

Procedure

1. Have the vacuum pump part number to hand, along with other details from the rating plate.
2. Install original spare parts only.

Spare parts package	Pump type	Order number
Set of seals	Hena 401 Hena 631	PK E60 024 -T
Maintenance kit	Hena 401 Hena 631	PK E61 023 -T
Inspection set without vane	Hena 401	PK E62 026 -T
	Hena 631	PK E62 027 -T
Set of vanes	Hena 401	PK E68 026 -T
	Hena 631	PK E68 027 -T
Operating fluid filter	Hena 401 Hena 631	P 0920 549 E
Gas ballast filter	Hena 401 Hena 631	PK 100 172 -U
Pressure gage, 0 – 1000 hPa	Hena 401 Hena 631	PK 100 128
Temperature switch for exhaust air temperature	Hena 401 Hena 631	PK 100 135 -T

Tbl. 13: Spare parts packages

12.2 Operating fluids – Maintenance level 1

Select the respective operating fluid type and quantity under consideration of the details on the rating plate.

Description	Order number
P3, mineral oil, 1 l	PK 001 106 -T
P3, mineral oil, 5 l	PK 001 107 -T
P3, mineral oil, 20 l	PK 001 108 -T
D1, synthetic diester based oil, 1 l	PK 005 875 -T
D1, synthetic diester based oil, 5 l	PK 005 876 -T

Tbl. 14: Consumables

12.3 Maintenance kit – maintenance level 1

The maintenance kit contains:

- Filler and drain screw seals for one operating fluid change
- Seals of the separator cover plate for cleaning the oil chamber
- Exhaust filter
- Operating fluid filter
- Filter material

12.4 Overhaul kit – maintenance level 3

The overhaul kit contains all the wear parts of the vacuum pump that must be replaced after the vacuum pump has been dismantled and cleaned:

- Set of seals with all seals relevant for the function
- Bearing
- Intake strainer
- Operating fluid and exhaust filters
- Wearing parts of the valves
- Coupling sleeve

12.5 Set of seals

The set of seals contains:

- all seals from the main- and sub-assemblies,
- Radial shaft seal rings (RSSR)

12.6 Set of vanes

The set of vanes contains:

- Vane



13 Accessories



View the [range of accessories for rotary vane pumps](#) on our website.

13.1 Accessory information

Operating fluid level switch

Monitors operating fluid level

Operating fluid temperature switch

Monitors operating fluid temperature

Screwing flange

Enables the connection of components with ISO-K

Condensate separator

Protects the pump from liquids from inlet line or backflow from exhaust line

Dust separators

Protects the pump from particles out of processes

Magnetized gas ballast valve

Solenoid valve for remote control of gas ballast

PTC resistor tripping device

Monitors the motor winding temperature

13.2 Ordering accessories

Description	Part number
Operating Fluid Level Switch	PK 100 116
Operating Fluid Temperature Switch	PK 100 125
KAS 100, Condensate Separator	PK Z10 012
SAS 100, DN 100 ISO-K	PK Z60 512
Screw-in flange DN 100 ISO-K	PK 100 061
PTC Resistor Tripping Device 220 – 240 V AC	P 4768 052 FQ
PTC Resistor Tripping Device 24 V AC/DC	P 4768 052 FE
Magnetic Gas Ballast Valve 24 VDC	PK 100 141 -U

Tbl. 15: Accessories



14 Technical data and dimensions

14.1 General

Basis for the technical data of Pfeiffer Vacuum rotary vane pumps:

- Specifications according to PNEUROP committee PN5
- ISO 21360-1: 2016: "Vacuum technology - Standard methods for measuring vacuum-pump performance - Part 1: General description"
- Leak test to ascertain the integral leakage rate according to EN 1779: 1999 technique A1; with 20 % helium concentration, 10 s measurement duration
- Sound pressure level according to ISO 3744, class 2

	mbar	bar	Pa	hPa	kPa	Torr mm Hg
mbar	1	$1 \cdot 10^{-3}$	100	1	0.1	0.75
bar	1000	1	$1 \cdot 10^5$	1000	100	750
Pa	0.01	$1 \cdot 10^{-5}$	1	0.01	$1 \cdot 10^{-3}$	$7.5 \cdot 10^{-3}$
hPa	1	$1 \cdot 10^{-3}$	100	1	0.1	0.75
kPa	10	0.01	1000	10	1	7.5
Torr mm Hg	1.33	$1.33 \cdot 10^{-3}$	133.32	1.33	0.133	1

1 Pa = 1 N/m²

Tbl. 16: Conversion table: Pressure units

	mbar l/s	Pa m ³ /s	sccm	Torr l/s	atm cm ³ /s
mbar l/s	1	0.1	59.2	0.75	0.987
Pa m ³ /s	10	1	592	7.5	9.87
sccm	$1.69 \cdot 10^{-2}$	$1.69 \cdot 10^{-3}$	1	$1.27 \cdot 10^{-2}$	$1.67 \cdot 10^{-2}$
Torr l/s	1.33	0.133	78.9	1	1.32
atm cm ³ /s	1.01	0.101	59.8	0.76	1

Tbl. 17: Conversion table: Units for gas throughput

14.2 Technical data

Classification	Hena 401	Hena 401	Hena 401	Hena 401	Hena 401
Part number	PK D03 500	PK D04 171 111	PK D04 171 112	PK D04 171 121	PK D04 171 122
Nominal pumping speed at 50 Hz	400 m ³ /h	410 m ³ /h	410 m ³ /h	410 m ³ /h	410 m ³ /h
Nominal pumping speed at 60 Hz	480 m ³ /h	480 m ³ /h	480 m ³ /h	480 m ³ /h	480 m ³ /h
Final pressure with gas ballast	$\leq 7 \cdot 10^{-1}$ hPa	≤ 1.5 hPa	$\leq 5 \cdot 10^{-1}$ hPa	≤ 1.5 hPa	$\leq 5 \cdot 10^{-1}$ hPa
Final pressure without gas ballast	$\leq 3 \cdot 10^{-1}$ hPa	$\leq 5 \cdot 10^{-1}$ hPa	$\leq 1 \cdot 10^{-1}$ hPa	$\leq 5 \cdot 10^{-1}$ hPa	$\leq 1 \cdot 10^{-1}$ hPa
Continuous inlet pressure, max.	800 hPa	800 hPa	800 hPa	800 hPa	800 hPa
Leak rate safety valve	$\leq 8 \cdot 10^{-3}$ Pa m ³ /s	$\leq 8 \cdot 10^{-3}$ Pa m ³ /s	$\leq 8 \cdot 10^{-3}$ Pa m ³ /s	$\leq 8 \cdot 10^{-3}$ Pa m ³ /s	$\leq 8 \cdot 10^{-3}$ Pa m ³ /s
Exhaust pressure, max.	Atmospheric pressure	Atmospheric pressure	Atmospheric pressure	Atmospheric pressure	Atmospheric pressure
Exhaust pressure, min.	Atmospheric pressure	Atmospheric pressure	Atmospheric pressure	Atmospheric pressure	Atmospheric pressure
Water vapor capacity 50 Hz	9000 g/h	9000 g/h	9000 g/h	9000 g/h	9000 g/h



Classification	Hena 401	Hena 401	Hena 401	Hena 401	Hena 401
Water vapor capacity 60 Hz	11000 g/h	11000 g/h	11000 g/h	11000 g/h	11000 g/h
Water vapor tolerance at 50 Hz	40 hPa	40 hPa	40 hPa	40 hPa	40 hPa
Water vapor tolerance at 60 Hz	40 hPa	40 hPa	40 hPa	40 hPa	40 hPa
Emission sound pressure level without gas ballast at 50 Hz	≤ 77 dB(A)	≤ 77 dB(A)	≤ 77 dB(A)	≤ 77 dB(A)	≤ 77 dB(A)
Emission sound pressure level without gas ballast at 60 Hz	≤ 79 dB(A)	≤ 79 dB(A)	≤ 79 dB(A)	≤ 79 dB(A)	≤ 79 dB(A)
Cooling method, standard	Air	Air	Air	Air	Air
Continuous gas temperature, max.	80 °C	80 °C	80 °C	80 °C	80 °C
Operating fluid amount	12 l	12 l	12 l	12 l	12 l
Ambient temperature	12 – 40 °C	5 – 40 °C	5 – 35 °C	5 – 40 °C	5 – 35 °C
Shipping and storage temperature	-25 – 55 °C	-25 – 55 °C	-25 – 55 °C	-25 – 55 °C	-25 – 55 °C
Motor version	3-ph motor	3-ph motor	3-ph motor	3-ph motor	3-ph motor
Input voltage 50 Hz	190 – 200 / 220 – 230 / 380 – 400 V	190 – 200 / 220 – 230 / 380 – 400 V	190 – 200 / 220 – 230 / 380 – 400 V	200 / 346 V	200 / 346 V
Input voltage 60 Hz	208 / 220 / 230 / 440 / 460 V	208 / 220 / 230 / 440 / 460 V	208 / 220 / 230 / 440 / 460 V	220 / 380 V	220 / 380 V
Input voltage: tolerance	±5 %	±5 %	±5 %	±5 %	±5 %
Rated power 50 Hz	13.5 kW	13.5 kW	13.5 kW	13.5 kW	13.5 kW
Rated power 60 Hz	15 kW	15 kW	15 kW	15 kW	15 kW
Rotation speed at 50 Hz	1000 rpm	1000 rpm	1000 rpm	1000 rpm	1000 rpm
Rotation speed at 60 Hz	1200 rpm	1200 rpm	1200 rpm	1200 rpm	1200 rpm
Protection category	IP55	IP55	IP55	IP55	IP55
Motor protection	PTC	PTC	PTC	PTC	PTC
Switch	No	No	No	No	No
Mains cable	No	No	No	No	No
Weight	554 kg	554 kg	554 kg	554 kg	554 kg

Tbl. 18: Hena 401 with air cooling

Classification	Hena 401	Hena 401	Hena 401	Hena 401
Part number	PK D04 171 211	PK D04 171 212	PK D04 171 221	PK D04 171 222
Nominal pumping speed at 50 Hz	410 m³/h	410 m³/h	410 m³/h	410 m³/h
Nominal pumping speed at 60 Hz	480 m³/h	480 m³/h	480 m³/h	480 m³/h
Final pressure with gas ballast	≤ 1.5 hPa	≤ 5 · 10 ⁻¹ hPa	≤ 1.5 hPa	≤ 5 · 10 ⁻¹ hPa
Final pressure without gas ballast	≤ 5 · 10 ⁻¹ hPa	≤ 1 · 10 ⁻¹ hPa	≤ 5 · 10 ⁻¹ hPa	≤ 1 · 10 ⁻¹ hPa
Continuous inlet pressure, max.	800 hPa	800 hPa	800 hPa	800 hPa
Leak rate safety valve	≤ 8 · 10 ⁻³ Pa m³/s	≤ 8 · 10 ⁻³ Pa m³/s	≤ 8 · 10 ⁻³ Pa m³/s	≤ 8 · 10 ⁻³ Pa m³/s
Exhaust pressure, max.	Atmospheric pressure	Atmospheric pressure	Atmospheric pressure	Atmospheric pressure
Exhaust pressure, min.	Atmospheric pressure	Atmospheric pressure	Atmospheric pressure	Atmospheric pressure
Water vapor capacity 50 Hz	9000 g/h	9000 g/h	9000 g/h	9000 g/h
Water vapor capacity 60 Hz	11000 g/h	11000 g/h	11000 g/h	11000 g/h
Water vapor tolerance at 50 Hz	40 hPa	40 hPa	40 hPa	40 hPa
Water vapor tolerance at 60 Hz	40 hPa	40 hPa	40 hPa	40 hPa



Technical data and dimensions

Classification	Hena 401	Hena 401	Hena 401	Hena 401
Emission sound pressure level without gas ballast at 50 Hz	≤ 77 dB(A)	≤ 77 dB(A)	≤ 77 dB(A)	≤ 77 dB(A)
Emission sound pressure level without gas ballast at 60 Hz	≤ 79 dB(A)	≤ 79 dB(A)	≤ 79 dB(A)	≤ 79 dB(A)
Cooling method, standard	Water	Water	Water	Water
Continuous gas temperature, max.	80 °C	80 °C	80 °C	80 °C
Operating fluid amount	12 l	12 l	12 l	12 l
Ambient temperature	5 – 40 °C	5 – 35 °C	5 – 40 °C	5 – 35 °C
Shipping and storage temperature	-25 – 55 °C	-25 – 55 °C	-25 – 55 °C	-25 – 55 °C
Motor version	3-ph motor	3-ph motor	3-ph motor	3-ph motor
Input voltage 50 Hz	190 – 200 / 220 – 230 / 380 – 400 V	190 – 200 / 220 – 230 / 380 – 400 V	200 / 346 V	200 / 346 V
Input voltage 60 Hz	208 / 220 / 230 / 440 / 460 V	208 / 220 / 230 / 440 / 460 V	220 / 380 V	220 / 380 V
Input voltage: tolerance	±5 %	±5 %	±5 %	±5 %
Rated power 50 Hz	13.5 kW	13.5 kW	13.5 kW	13.5 kW
Rated power 60 Hz	15 kW	15 kW	15 kW	15 kW
Rotation speed at 50 Hz	1000 rpm	1000 rpm	1000 rpm	1000 rpm
Rotation speed at 60 Hz	1200 rpm	1200 rpm	1200 rpm	1200 rpm
Protection category	IP55	IP55	IP55	IP55
Motor protection	PTC	PTC	PTC	PTC
Switch	No	No	No	No
Mains cable	No	No	No	No
Weight	554 kg	554 kg	554 kg	554 kg

Tbl. 19: Hena 401 with water cooling

Classification	Hena 631	Hena 631	Hena 631	Hena 631	Hena 631
Part number	PK D03 600	PK D04 181 111	PK D04 181 112	PK D04 181 121	PK D04 181 122
Nominal pumping speed at 50 Hz	630 m ³ /h	630 m ³ /h	630 m ³ /h	630 m ³ /h	630 m ³ /h
Nominal pumping speed at 60 Hz	760 m ³ /h	760 m ³ /h	760 m ³ /h	760 m ³ /h	760 m ³ /h
Final pressure with gas ballast	≤ 7 · 10 ⁻¹ hPa	≤ 1.5 hPa	≤ 5 · 10 ⁻¹ hPa	≤ 1.5 hPa	≤ 5 · 10 ⁻¹ hPa
Final pressure without gas ballast	≤ 3 · 10 ⁻¹ hPa	≤ 5 · 10 ⁻¹ hPa	≤ 1 · 10 ⁻¹ hPa	≤ 5 · 10 ⁻¹ hPa	≤ 1 · 10 ⁻¹ hPa
Continuous inlet pressure, max.	800 hPa	800 hPa	800 hPa	800 hPa	800 hPa
Leak rate safety valve	≤ 8 · 10 ⁻³ Pa m ³ /s	≤ 8 · 10 ⁻³ Pa m ³ /s	≤ 8 · 10 ⁻³ Pa m ³ /s	≤ 8 · 10 ⁻³ Pa m ³ /s	≤ 8 · 10 ⁻³ Pa m ³ /s
Exhaust pressure, max.	Atmospheric pressure	Atmospheric pressure	Atmospheric pressure	Atmospheric pressure	Atmospheric pressure
Exhaust pressure, min.	Atmospheric pressure	Atmospheric pressure	Atmospheric pressure	Atmospheric pressure	Atmospheric pressure
Water vapor capacity 50 Hz	18000 g/h	18000 g/h	18000 g/h	18000 g/h	18000 g/h
Water vapor capacity 60 Hz	22000 g/h	22000 g/h	22000 g/h	22000 g/h	22000 g/h
Water vapor tolerance at 50 Hz	40 hPa	40 hPa	40 hPa	40 hPa	40 hPa
Water vapor tolerance at 60 Hz	40 hPa	40 hPa	40 hPa	40 hPa	40 hPa



Classification	Hena 631	Hena 631	Hena 631	Hena 631	Hena 631
Emission sound pressure level without gas ballast at 50 Hz	≤ 77 dB(A)	≤ 77 dB(A)	≤ 77 dB(A)	≤ 77 dB(A)	≤ 77 dB(A)
Emission sound pressure level without gas ballast at 60 Hz	≤ 79 dB(A)	≤ 79 dB(A)	≤ 79 dB(A)	≤ 79 dB(A)	≤ 79 dB(A)
Cooling method, standard	Air	Air	Air	Air	Air
Continuous gas temperature, max.	80 °C	80 °C	80 °C	80 °C	80 °C
Operating fluid amount	15 l	15 l	15 l	15 l	15 l
Ambient temperature	12 – 40 °C	5 – 40 °C	5 – 35 °C	5 – 40 °C	5 – 35 °C
Shipping and storage temperature	-25 – 55 °C	-25 – 55 °C	-25 – 55 °C	-25 – 55 °C	-25 – 55 °C
Motor version	3-ph motor	3-ph motor	3-ph motor	3-ph motor	3-ph motor
Input voltage 50 Hz	190 – 200 / 220 – 230 / 380 – 400 V	190 – 200 / 220 – 230 / 380 – 400 V	190 – 200 / 220 – 230 / 380 – 400 V	200 / 346 V	200 / 346 V
Input voltage 60 Hz	208 / 220 / 230 / 440 / 460 V	208 / 220 / 230 / 440 / 460 V	208 / 220 / 230 / 440 / 460 V	220 / 380 V	220 / 380 V
Input voltage: tolerance	±5 %	±5 %	±5 %	±5 %	±5 %
Rated power 50 Hz	15 kW	15 kW	15 kW	15 kW	15 kW
Rated power 60 Hz	18.5 kW	18.5 kW	18.5 kW	18.5 kW	18.5 kW
Rotation speed at 50 Hz	1000 rpm	1000 rpm	1000 rpm	1000 rpm	1000 rpm
Rotation speed at 60 Hz	1200 rpm	1200 rpm	1200 rpm	1200 rpm	1200 rpm
Protection category	IP55	IP55	IP55	IP55	IP55
Motor protection	PTC	PTC	PTC	PTC	PTC
Switch	No	No	No	No	No
Mains cable	No	No	No	No	No
Weight	706 kg	706 kg	706 kg	706 kg	706 kg

Tbl. 20: Hena 631 with air cooling

Classification	Hena 631	Hena 631	Hena 631	Hena 631	Hena 631
Part number	PK D03 610	PK D04 181 211	PK D04 181 212	PK D04 181 221	PK D04 181 222
Nominal pumping speed at 50 Hz	630 m ³ /h	630 m ³ /h	630 m ³ /h	630 m ³ /h	630 m ³ /h
Nominal pumping speed at 60 Hz	760 m ³ /h	760 m ³ /h	760 m ³ /h	760 m ³ /h	760 m ³ /h
Final pressure with gas ballast	≤ 7 · 10 ⁻¹ hPa	≤ 1.5 hPa	≤ 5 · 10 ⁻¹ hPa	≤ 1.5 hPa	≤ 5 · 10 ⁻¹ hPa
Final pressure without gas ballast	≤ 3 · 10 ⁻¹ hPa	≤ 5 · 10 ⁻¹ hPa	≤ 1 · 10 ⁻¹ hPa	≤ 5 · 10 ⁻¹ hPa	≤ 1 · 10 ⁻¹ hPa
Continuous inlet pressure, max.	800 hPa	800 hPa	800 hPa	800 hPa	800 hPa
Leak rate safety valve	≤ 8 · 10 ⁻³ Pa m ³ /s	≤ 8 · 10 ⁻³ Pa m ³ /s	≤ 8 · 10 ⁻³ Pa m ³ /s	≤ 8 · 10 ⁻³ Pa m ³ /s	≤ 8 · 10 ⁻³ Pa m ³ /s
Exhaust pressure, max.	Atmospheric pressure	Atmospheric pressure	Atmospheric pressure	Atmospheric pressure	Atmospheric pressure
Exhaust pressure, min.	Atmospheric pressure	Atmospheric pressure	Atmospheric pressure	Atmospheric pressure	Atmospheric pressure
Water vapor capacity 50 Hz	18000 g/h	18000 g/h	18000 g/h	18000 g/h	18000 g/h
Water vapor capacity 60 Hz	22000 g/h	22000 g/h	22000 g/h	22000 g/h	22000 g/h



Technical data and dimensions

Classification	Hena 631	Hena 631	Hena 631	Hena 631	Hena 631
Water vapor tolerance at 50 Hz	40 hPa	40 hPa	40 hPa	40 hPa	40 hPa
Water vapor tolerance at 60 Hz	40 hPa	40 hPa	40 hPa	40 hPa	40 hPa
Emission sound pressure level without gas ballast at 50 Hz	≤ 77 dB(A)	≤ 77 dB(A)	≤ 77 dB(A)	≤ 77 dB(A)	≤ 77 dB(A)
Emission sound pressure level without gas ballast at 60 Hz	≤ 79 dB(A)	≤ 79 dB(A)	≤ 79 dB(A)	≤ 79 dB(A)	≤ 79 dB(A)
Cooling method, standard	Water	Water	Water	Water	Water
Cooling water pressure	2 000 – 6 000 hPa	2 000 – 6 000 hPa	2 000 – 6 000 hPa	2 000 – 6 000 hPa	2 000 – 6 000 hPa
Cooling water flow	300 l/h	300 l/h	300 l/h	300 l/h	300 l/h
Cooling water temperature	5 – 35 °C	5 – 35 °C	5 – 35 °C	5 – 35 °C	5 – 35 °C
Continuous gas temperature, max.	80 °C	80 °C	80 °C	80 °C	80 °C
Operating fluid amount	15 l	15 l	15 l	15 l	15 l
Ambient temperature	12 – 40 °C	5 – 40 °C	5 – 35 °C	5 – 40 °C	5 – 35 °C
Shipping and storage temperature	-25 – 55 °C	-25 – 55 °C	-25 – 55 °C	-25 – 55 °C	-25 – 55 °C
Motor version	3-ph motor	3-ph motor	3-ph motor	3-ph motor	3-ph motor
Input voltage 50 Hz	190 – 200 / 220 – 230 / 380 – 400 V	190 – 200 / 220 – 230 / 380 – 400 V	190 – 200 / 220 – 230 / 380 – 400 V	200 / 346 V	200 / 346 V
Input voltage 60 Hz	208 / 220 / 230 / 440 / 460 V	208 / 220 / 230 / 440 / 460 V	208 / 220 / 230 / 440 / 460 V	220 / 380 V	220 / 380 V
Input voltage: tolerance	±5 %	±5 %	±5 %	±5 %	±5 %
Rated power 50 Hz	15 kW	15 kW	15 kW	15 kW	15 kW
Rated power 60 Hz	18.5 kW	18.5 kW	18.5 kW	18.5 kW	18.5 kW
Rotation speed at 50 Hz	1000 rpm	1000 rpm	1000 rpm	1000 rpm	1000 rpm
Rotation speed at 60 Hz	1200 rpm	1200 rpm	1200 rpm	1200 rpm	1200 rpm
Protection category	IP55	IP55	IP55	IP55	IP55
Motor protection	PTC	PTC	PTC	PTC	PTC
Switch	No	No	No	No	No
Mains cable	No	No	No	No	No
Weight	670 kg	670 kg	670 kg	670 kg	670 kg

Tbl. 21: Hena 631 with water cooling



14.3 Dimensions

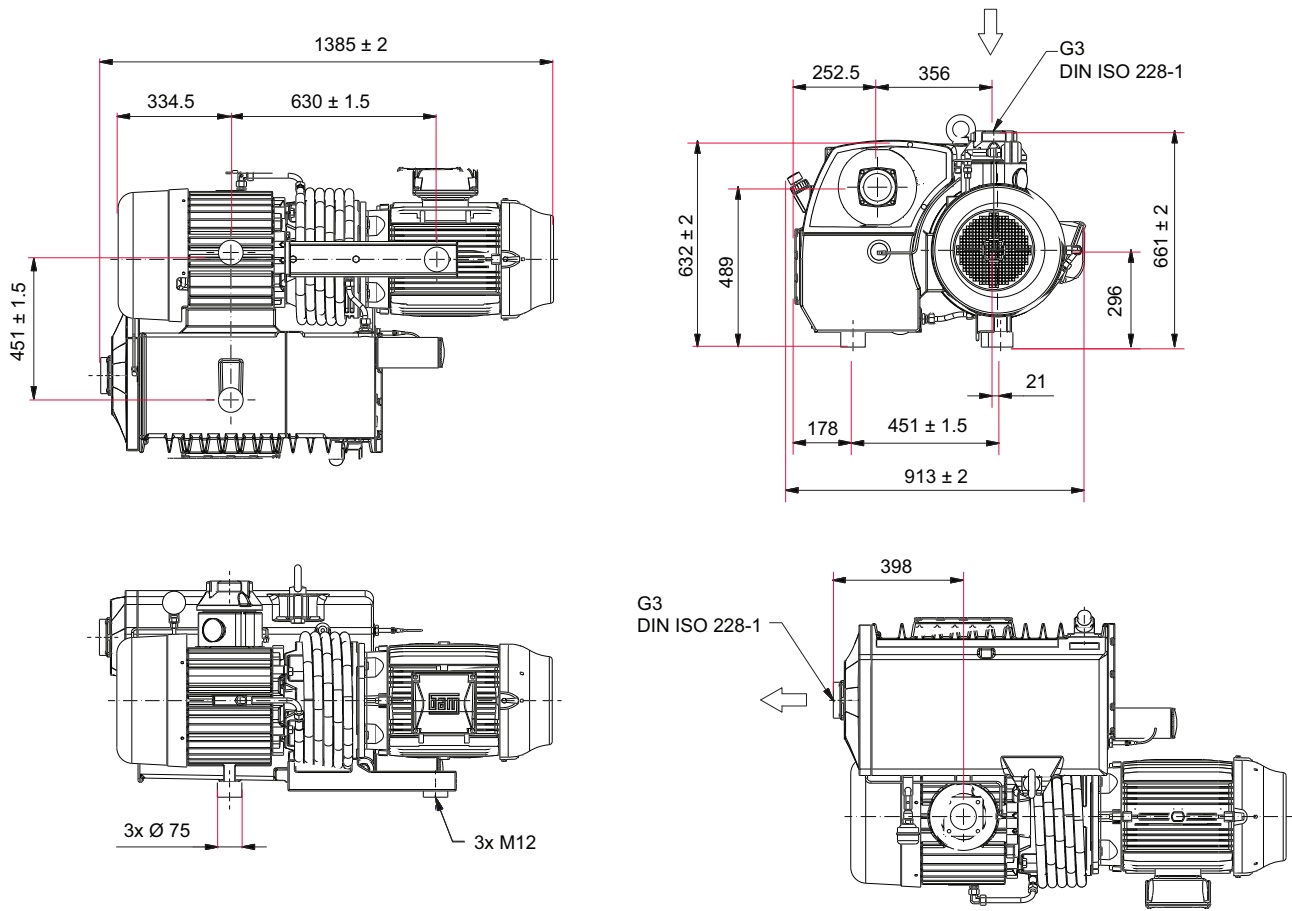

Fig. 25: Dimensions Hena 401 with air cooling | Three phase motor IE3
 Dimensions in mm



Technical data and dimensions

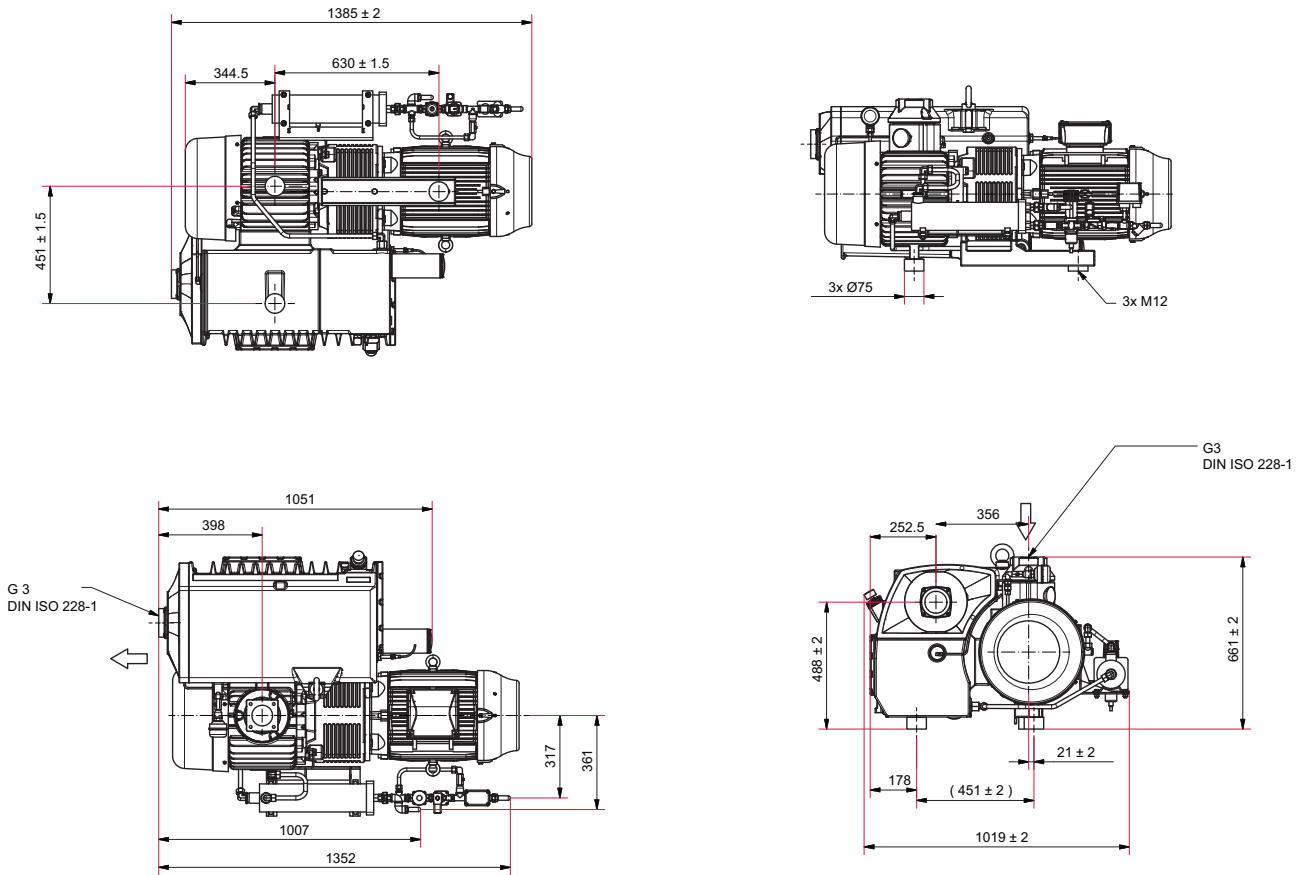

Fig. 26: Dimensions Hena 401 S with water cooling | Three phase motor IE3
Dimensions in mm



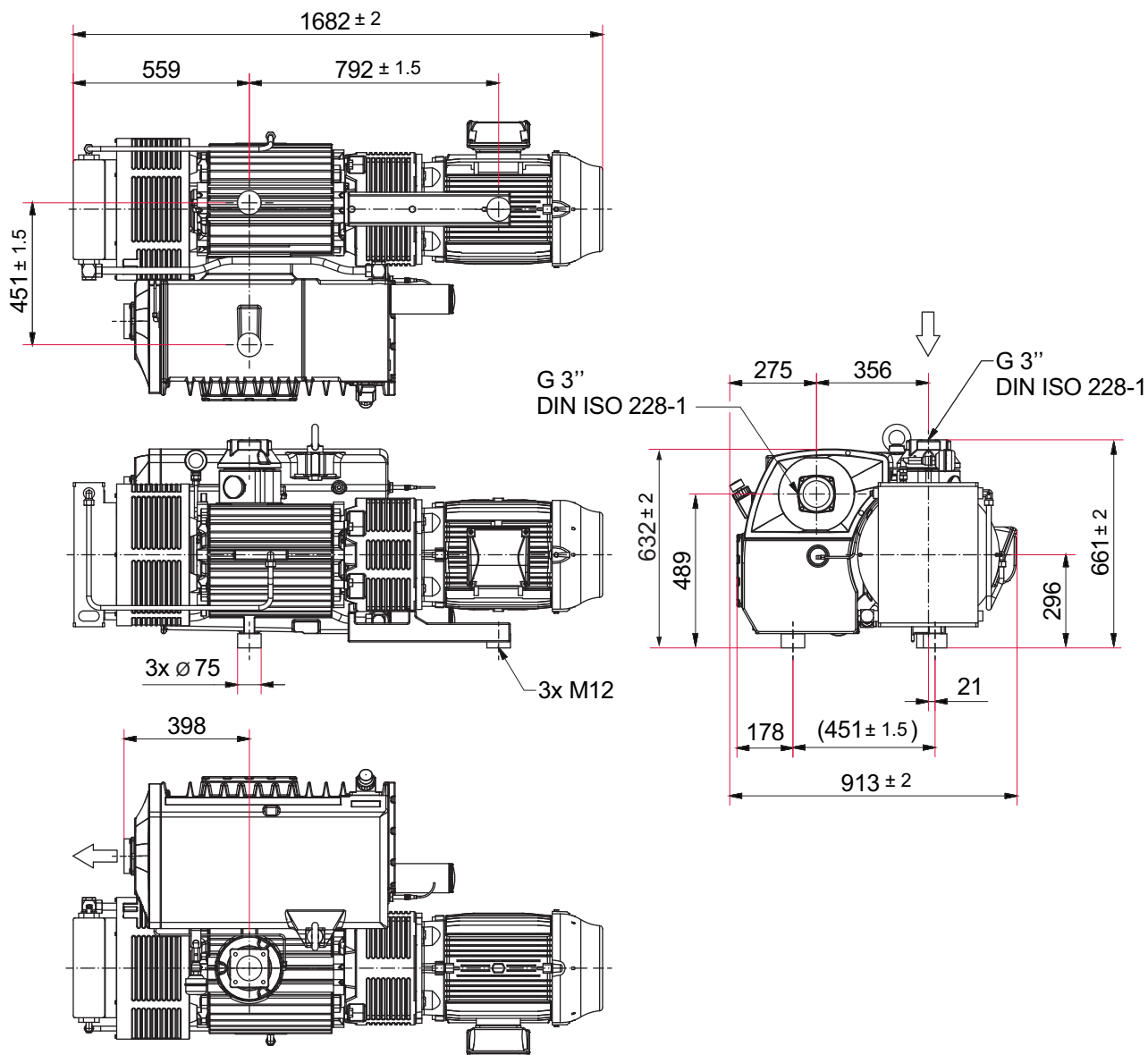

Fig. 27: Dimensions Hena 631 with air cooling | Three phase motor IE3
Dimensions in mm



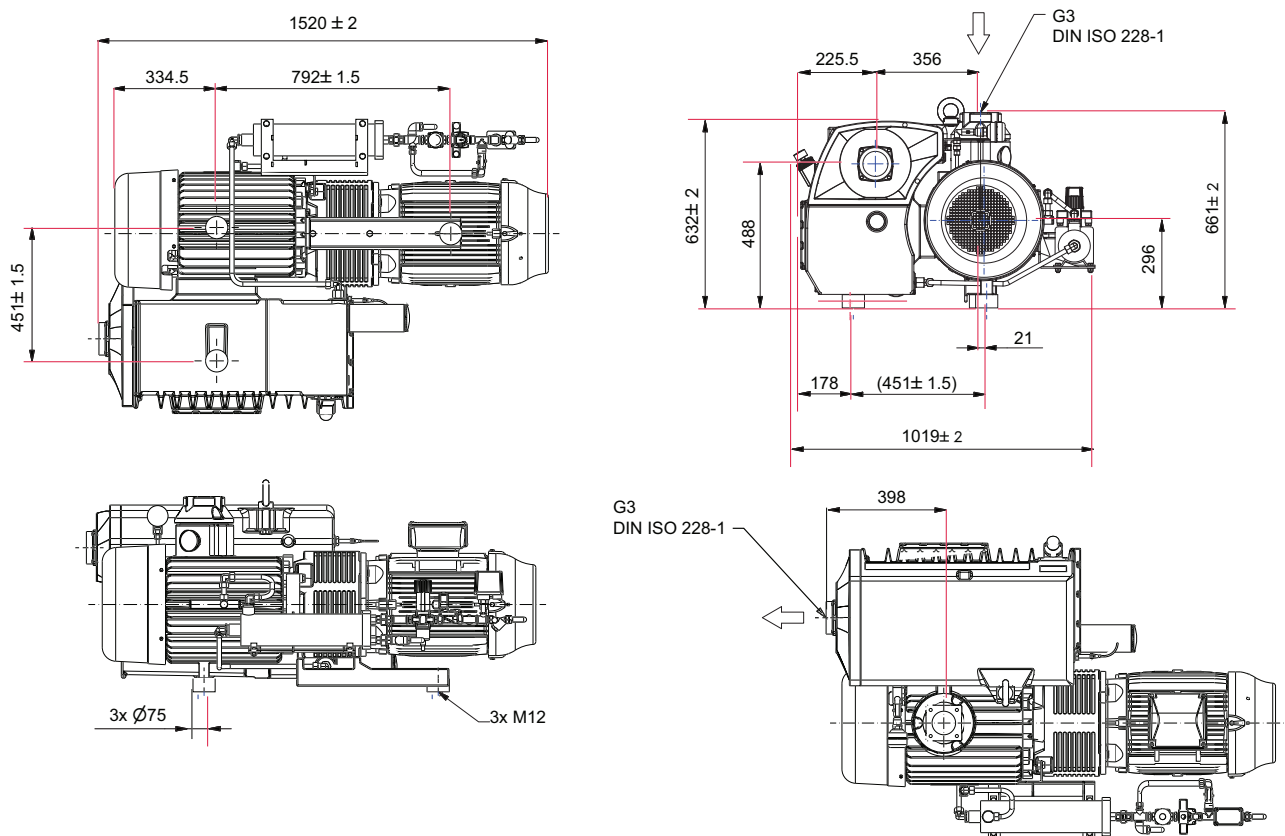

Fig. 28: Dimensions Hena 631 S with water cooling | Three phase motor IE3
Dimensions in mm



Declaration of conformity

Declaration for product(s) of the type:

Rotary vane pump

Hena 401

Hena 631

We hereby declare that the listed product satisfies all relevant provisions of the following **European Directives**.

Machinery 2006/42/EC (Annex II, no. 1 A)

Electromagnetic compatibility 2014/30/EU

Restriction of the use of certain hazardous substances 2011/65/EU

Restriction of the use of certain hazardous substances, delegated directive 2015/863/EU

Harmonized standards and applied national standards and specifications:

DIN EN ISO 12100: 2011-03

DIN EN 60204-1: 2019-06

DIN EN ISO 13857: 2008-06

DIN EN 61000-6-2: 2006-03

DIN EN 1012-1: 2011-02

DIN EN 61000-6-4: 2011-09

DIN EN 1012-2 : 2011-12

DIN EN ISO 2151 : 2009-01

DIN EN 13849-1: 2016-06

The authorized representative for the compilation of technical documents is Mr. Wolfgang Bremer, Pfeiffer Vacuum GmbH, Berliner Straße 43, 35614 Asslar, Germany.

Signature:



(Daniel Sälzer)
Managing Director

Pfeiffer Vacuum GmbH
Berliner Straße 43
35614 Asslar
Germany

Asslar, 2020-05-26



VACUUM SOLUTIONS FROM A SINGLE SOURCE

Pfeiffer Vacuum stands for innovative and custom vacuum solutions worldwide, technological perfection, competent advice and reliable service.

COMPLETE RANGE OF PRODUCTS

From a single component to complex systems:

We are the only supplier of vacuum technology that provides a complete product portfolio.

COMPETENCE IN THEORY AND PRACTICE

Benefit from our know-how and our portfolio of training opportunities!

We support you with your plant layout and provide first-class on-site service worldwide.

ed. D - Date 2008 - P/N:PD00088BEN



Are you looking for a
perfect vacuum solution?
Please contact us

Pfeiffer Vacuum GmbH
Headquarters • Germany
T +49 6441 802-0
info@pfeiffer-vacuum.de

www.pfeiffer-vacuum.com

PFEIFFER  **VACUUM**

